

**COMMUNICATIONS
ALLIANCE LTD**



AUSTRALIAN STANDARD

AS/CA S004:2013

Voice performance requirements for Customer
Equipment

Australian Standard – Voice performance requirements for Customer Equipment

This Standard was issued in draft form for public comment as DR AS/CA S004:2012.

First published as AS/ACIF S004:1999

Second edition AS/ACIF S004:2001

Third edition AS/ACIF S004:2004

Fourth edition AS/ACIF S004:2006

Fifth edition AS/ACIF S004:2008

ISBN: 1 74000 420 5

Communications Alliance Ltd was formed in 2006 to provide a unified voice for the Australian communications industry and to lead it into the next generation of converging networks, technologies and services. ACIF is a division of Communications Alliance.

Disclaimers

1. Notwithstanding anything contained in this Standard:
 - (a) Communications Alliance disclaims responsibility (including where Communications Alliance or any of its officers, employees, agents or contractors has been negligent) for any direct or indirect loss, damage, claim, or liability any person may incur as a result of any:
 - (i) reliance on or compliance with this Standard;
 - (ii) inaccuracy or inappropriateness of this Standard; or
 - (iii) inconsistency of this Standard with any law; and
 - (b) Communications Alliance disclaims responsibility (including where Communications Alliance or any of its officers, employees, agents or contractors has been negligent) for ensuring compliance by any person with this Industry.
2. The above disclaimers will not apply to the extent they are inconsistent with any relevant legislation.

Copyright

© Communications Alliance 2013

This document is copyright and must not be used except as permitted below or under the Copyright Act 1968. You may reproduce and publish this document in whole or in part for your or your organisation's own personal or internal compliance, educational or non-commercial purposes. You must not alter or amend this document in any way. You must not reproduce or publish this document for commercial gain without the prior written consent of Communications Alliance. Organisations wishing to reproduce or publish this document for commercial gain (i.e. for distribution to subscribers to an information service) should apply to Communications Alliance by contacting the Communications Alliance Commercial Manager at info@commsalliance.com.au.

FOREWORD

General

This Standard has been prepared by Communications Alliance, and most recently revised by the *WC41 Voice Frequency Performance Revision Working Committee*. It is one of a series of Telecommunication Standards developed under the Memorandum of Understanding between the Australian Communications Authority (ACA) and the Australian Communications Industry Forum.

Note: On 1 July 2005 the ACA became the Australian Communications and Media Authority (ACMA) and the Memorandum of Understanding continues in effect as if the reference to the ACA were a reference to ACMA.

This Standard is a revision of *AS/ACIF S004:2008 Voice frequency performance requirements for Customer Equipment*. This Standard is the result of a consensus among representatives on the Communications Alliance Working Committee to produce it as an Australian Standard.

The requirements in this Standard are consistent with the aims of s376 of the *Telecommunications Act 1997*. Specifically these aims are—

- (a) protecting the integrity of a telecommunications network or facility;
- (b) protecting the health and safety of persons;
- (c) ensuring access to emergency services; and
- (d) ensuring interoperability with a standard telephone service.

It should be noted that some Customer Equipment (CE) may also need to comply with requirements in other Standards.

Applicable electrical safety Standards and EMC Standards may apply under Commonwealth or State laws, or both.

Intellectual property rights

Equipment which is manufactured to comply with this Standard may require the use of technology which is protected by patent rights in Australia. Questions about the availability of such technology, under licence or otherwise, should be directed to the patent holder or Australian licensee (if known) or through enquiry at IP Australia which incorporates the Patent, Designs and Trade Marks Offices. Further information can be found at www.ipaustralia.gov.au.

Standards revision

Australian Standards (AS/ACIF and AS/CA Standards) developed by the Communications Alliance are updated according to the needs of the industry, by amendments or revision. Users of these Standards should make sure that they possess the latest amendments or editions. Representations concerning the need for a change to this AS/CA Standard should be addressed to—

The Project Manager
Customer Equipment and Cable Reference Panel
Communications Alliance
PO Box 444
Milsons Point NSW 1565

Regulatory notice

This document will be submitted to the ACMA, for making as a technical standard under s376 of the *Telecommunications Act 1997*. Until it is made by the ACMA compliance with this Standard is voluntary.

ACMA is a Commonwealth authority with statutory powers to impose requirements concerning telecommunications Customer Equipment and Customer Cabling.

ACMA requires Australian manufacturers and importers of specified items of Customer Equipment and Customer Cabling to establish compliance with Standards such as this. Items are required to be labelled to the applicable labelling notices.

Details on current compliance arrangements can be obtained from the ACMA website at <http://www.acma.gov.au> or by contacting ACMA below at:

Australian Communications and Media Authority
PO Box 13112
Law Courts PO
Melbourne VIC 8010
Australia

Telephone: +61 3 9963 6800
Facsimile: +61 3 9963 6899
TTY: +61 3 9963 6948

INTRODUCTION

This introduction for the AS/CA S004 **Voice performance requirements for Customer Equipment** Standard is not an authoritative section of this Standard and is only provided as guidance for the user of the Standard to outline its objectives, and the factors that have been taken into account in its development and to list the principal differences between the new and the previous edition.

The reader is directed to the clauses of this Standard for the specific requirements and to the Australian Communications and Media Authority (ACMA) for the applicable telecommunications labelling and compliance arrangements.

Note: Further information on the telecommunications labelling and compliance arrangements can be found in *The Telecommunications Labelling (Customer Equipment and Customer Cabling) Notice* (the TLN). The TLN can be obtained from the Australian Communications and Media Authority (ACMA) website at www.acma.gov.au.

The objective of this Standard is to provide the requirements and test methods for customer equipment that is designed or intended to transmit and receive voice frequency signals for voice communication, voice messages or tones over a telecommunications network, in order to meet the regulatory arrangements for such equipment in Australia.

The objective of this revision was to revise the requirements and test methods for maximum sound pressure level and to bring the Standard into alignment with other Customer Equipment Standards and international Standards.

The principal differences between this edition of AS/CA S004 and the previous edition include:

- (i) extending the maximum sound pressure level (SPL) and acoustic shock requirements to CE using any of the Wideband, Super Wideband, or Fullband frequency ranges as defined in ETSI Guide EG 202 518 for all frequency bands in which the CE can operate. The range for testing has been extended from 100 Hz to 8 kHz.
- (ii) the test frequency steps in the range from 900 Hz to 3 kHz have been increased to one-twelfth octave intervals. This now increases the overall number of frequency steps from seventeen to forty.
- (iii) the lower limit for the source voltage while testing for SPL has been lowered from 3 V to 100 mV r.m.s. to ensure that the maximum SPL is not exceeded at those lower test voltage levels, in particular for CE with AGC.
- (iv) the SPL test method now carried out using both the swept and the stepped pulse frequency methods.
- (v) the maximum sound pressure RMS levels for handsets and headsets are no longer A-weighted.
- (vi) incoming call alert signals are allowed to be directed to physical electrical interfaces for headsets and earphones as long as they do not exceed the maximum level for voice signals.

TABLE OF CONTENTS

1	INTERPRETATIVE GUIDELINES	1
	1.1 Categories of requirements	1
	1.2 Compliance statements	1
	1.3 Definitions, expressions and terms	1
	1.4 Notes	1
	1.5 References	1
	1.6 Units and symbols	1
2	SCOPE	2
3	REFERENCES	3
4	ABBREVIATIONS AND DEFINITIONS	5
	4.1 Abbreviations	5
	4.2 Definitions	5
5	REQUIREMENTS	9
	5.1 THIS CLAUSE LEFT BLANK	9
	5.2 Maximum signal level to analogue network line for speech and music	9
	5.3 Non-electro-acoustic transmission	9
	5.4 Electro-acoustic transmission and reception	10
	5.5 Acoustic coupling	19
6	TESTING	20
	6.1 General	20
	6.2 Standard test conditions	20
	6.3 Parameters to be tested	21
	PARTICIPANTS	46

APPENDICIES

A	Volume Unit Indicator	37
A1	Component parts	37
A2	Dynamic characteristics	37
A3	Response versus frequency characteristic	37
A4	Response to complex waves	37
A5	Reversibility	37
A6	Graduation of meter scale	37
A7	Attenuator	37
A8	Calibration	38
A9	Method of reading volume indicator	38
A.9.1	Duration of Measurement	38
A.9.2	Measurement relative to reference point	38
A.9.3	Correction to volume for impedance difference	38
B	Stepped Pulsed Stimuli For Time Dependent Limiting Test	39
B1	Introduction	39
B2	Test frequency list	40
B3	Telephone products tracks	40

FIGURES

1	Send frequency response mask – Acoustic input other than from handset or headset	27
2	Send frequency response mask for handset (Analogue Interface – 1.6 km of 0.40 mm copper cable)	27
3	Send frequency response mask for headset (Analogue Interface – 1.6 km of 0.40 mm copper cable)	27
4	Send frequency response mask for handset – Digital interface	28
5	Send frequency response mask for headset – Digital interface	28
6	Receive frequency response mask for handset – Analogue Interface (1.6 km of 0.40 mm copper cable) and Receive frequency response mask for handset – Digital interface	28
7	Receive frequency response mask for headset – Analogue Interface (1.6 km of 0.40 mm copper cable) and Receive frequency response mask for headset – Digital interface	29
8	Schematic for sending frequency response test	29
9	Schematic for sending frequency response test – Digital telephone	30
10	Schematic for receiving frequency response test	30
11	Schematic for receiving frequency response test – Digital telephone	30
12	Artificial line – Limit length (4.2 km of 0.40 mm cable or 7.0 km of 0.64 mm cable)	31

13	Artificial line – Average length (1.6 km of 0.40 mm cable or 2.5 km of 0.64 mm cable)	31
14	Artificial line – Short length (0.5 km of 0.40 mm cable or 0.5 km of 0.64 mm cable)	31
15	Test circuit for howling	32
16	Test circuit for continuous input – CE with analogue interface	32
17	Test circuit for continuous input – CE with digital interface	33
18	Test circuit for pulse input	33
19	Test circuit for transmission level and frequency response	34
20	Test equipment for testing the acoustic sound pressure level of acoustically coupled devices	35
21	Test circuit for independently supplied handset/headset	36
22	Test circuit for pulse input for independently supplied handset/headset	36

TABLES

1	Send and receive Loudness Ratings	13
2	Sidetone masking ratings	13
3	Maximum sound pressure levels	16
B1	Test frequency list	40
B2	Alignment tones	41
B3	Analogue telephone products track test sequence	42
B4	Digital products track test sequence	43
B5	Headset products track test sequence	44

1 INTERPRETATIVE GUIDELINES

1.1 Categories of requirements

This Standard contains mandatory requirements as well as provisions that are recommendatory only. Mandatory requirements are designated by the words '**shall**' or '**shall not**'. All other provisions are voluntary.

1.2 Compliance statements

Compliance statements, in italics, suggest methodologies for demonstrating CE's compliance with the requirements.

1.3 Definitions, expressions and terms

If there is any conflict between the definitions used in this Standard and the definitions used in the *Telecommunications Act 1997*, the definitions in the Act take precedence.

1.4 Notes

Text denoted as 'Note' is for guidance in interpretation and is shown in smaller size type.

1.5 References

- (a) Applicable editions (or versions) of other documents referred to in this Standard are specified in Section 3: REFERENCES.
- (b) If a document refers to another document, the other document is a sub-referenced document.
- (c) Where the edition (or version) of the sub-referenced document is uniquely identified in the reference document, then that edition (or version) applies.
- (d) Where the edition (or version) of the sub-referenced document is not uniquely identified in the reference document, then the applicable edition (or version) is that which is current at the date the reference document is legislated under the applicable regulatory framework, or for a non- legislated document, the date upon which the document is published by the relevant standards organisation.
- (e) A number in square brackets '[']' refers to a document listed in Section 3: REFERENCES.

1.6 Units and symbols

In this Standard the International System of units (SI) and symbols is used in accordance with Australian Standard AS ISO 1000 [1].

2 SCOPE

2.1 This Standard specifies the technical requirements for Customer Equipment (CE) that is designed or intended—

(a) to transmit and receive voice frequency signals for voice communication, voice messages or tones by direct or indirect electrical or electro acoustic means; and

(b) for connection to a Telecommunications Network.

2.2 CE is not excluded from the Scope of this Standard by reason only that the CE is capable of performing functions additional to those described in this Standard.

Note: AS/ACIF S040 [4] specifies the technical requirements for CE for use by persons with a disability.

3 REFERENCES

	Publication	Title
	Australian Standards	
[1]	AS ISO 1000-1998	The international System of Unit (SI) and its application.
	Communications Alliance/ACIF Standards	
[2]	AS/CA S002:2010 Amdt 1/2012	Analogue interworking and non-interference requirements for Customer Equipment for connection to the Public Switched Telephone Network
[3]	AS/CA S003:2010 AS/CA S003.1:2010 Amdt 1/2012 AS/CA S003.2:2010 AS/CA S003.3:2010	Requirements for Customer Access Equipment for connection to a Telecommunications Network Part 1: General Part 2: Analogue and TDM based technologies Part 3: Packet and cell based technologies
[4]	AS/ACIF S040:2001	Requirements for Customer Equipment for use with the Standard Telephone Service—Features for special needs of persons with disabilities
	Communications Alliance Guidelines	
[5]	G616:2013	Acoustic safety for telephone equipment
	ISO International Standards	
[6]	ISO 9614-1: 1993	Acoustics – Determination of sound power levels of noise sources using sound intensity – Part 1: Measurement at discrete points
	IEC Standards	
[7]	AS IEC 61672.1-2004	Electroacoustics - Sound level meters – Specifications
	ITU-T Recommendations	
[8]	G.711 (11/88)	Pulse code modulation (PCM) of voice frequencies
[9]	P.57 (12/2011)	Artificial ears

	Publication	Title
[10]	P.64 (11/2007)	Determination of sensitivity/frequency characteristics of local telephone systems
[11]	P.79 (11/2007)	Calculation of loudness ratings for telephone sets
[12]	P.310 (03/03)	Transmission characteristics for telephone band (300-3400 Hz) digital telephones
[13]	P.340 (03/04)	Transmission characteristics and speech quality parameters of handsfree telephones
[14]	P.380 (11/03)	Electro-acoustic measurements on headsets
[15]	P.1010 (07/04)	Fundamental voice transmission objectives for VoIP terminals and gateways
[16]	Handbook on Telephonometry	Edition 1992 Additions, Edition 1999 Addition to Section 3 - Edition 2002
ETSI Publications		
[17]	ES 201 168 V1.2.1 (2000-10)	Speech Processing, Transmission and Quality Aspects (STQ); Transmission characteristics of digital Private Branch eXchanges (PBXs) for interconnection to private networks, to the public switched network or to IP gateways
[18]	EG 202 518 (2010-01)	Speech and multimedia Transmission Quality (STQ); Acoustic Output of Terminal Equipment; Maximum Levels and Test Methodology for Various Applications
[19]	I-ETS 300 380 ed.1 (1995-03)	Universal Personal Telecommunication (UPT); Access devices Dual Tone Multi Frequency (DTMF) sender for acoustical coupling to the microphone of a handset telephone
[20]	I-ETS 300 480 ed.1 (1996-01)	Public Switched Telephone Network (PSTN); Testing specification for analogue handset telephony
ANSI Publications		
[21]	ANSI TIA/EIA-810-A	Telecommunications -- Telephone Terminal Equipment -- Transmission Requirements for Narrowband Voice over IP and Voice over PCM Digital Wireline Telephones

4 ABBREVIATIONS AND DEFINITIONS

For the purposes of this Standard, the following abbreviations, acronyms and definitions apply.

4.1 Abbreviations

ACMA	Australian Communications and Media Authority
AS	Australian Standard
CE	Customer Equipment
CODEC	Coder Decoder
CAE	Customer Access Equipment
DRP	Drum Reference Point
DTMF	Dual Tone Multifrequency
DUT	Device Under Test
ERP	Ear Reference Point
ETSI	European Telecommunications Standards Institute
IEC	International Electrotechnical Commission
ISDN	Integrated Services Digital Network
ISO	International Standardisation Organisation
ITU-T	International Telecommunication Union– Telecommunications Standardization Sector
PSTN	Public Switched Telephone Network
RLR	Receive Loudness Rating
RMS	Root Mean Square
SI	International System of Units
SLR	Send Loudness Rating
SPL	Sound Pressure Level
STM	Side Tone Masking Rating
STS	Standard Telephone Service
TCLw	Weighted Terminal Coupling Loss
VF	Voice Frequency
VoIP	Voice over Internet Protocol
VU	Volume Unit

4.2 Definitions

4.2.1 Acoustic Shock

Any temporary or permanent disturbance of the functioning of the ear, or of the nervous system, which may be caused to the user of a telephone earphone, by a sudden sharp rise in the acoustic pressure produced by it.

Note 1: Acoustic shock may include acoustic trauma, but can occur at sound levels considerably lower than those necessary to cause acoustic trauma.

Note 2: This definition is the one used by ETSI and ITU-T.

4.2.2 Acoustic trauma

Physiological damage to the auditory system that can occur near-instantaneously as a result of exposure to a very high intensity sound of typically brief duration.

4.2.3 Cordless

Cordless means no physical connection between a telephone headset or handset and a base unit which then provides the wired interface to the telecommunications network.

4.2.4 Customer Equipment (CE)

Refer to the *Telecommunications Act 1997*.

4.2.5 Customer Access Equipment (CAE)

CE with multiple ports (local or network) that provides access (gateway functions) to a Telecommunications Network and is capable of switching, storage, processing, conversion, integration, line isolation/coupling or multiplexing of analogue or digital voice or voice equivalent communication.

Note: Examples of CAE include, but are not limited to, PABX or Key Systems, line isolators, ISDN terminal adapters, echo cancellers, interactive voice response systems, voice/packet gateways, Integrated Access Devices and voice messaging systems.

4.2.6 Digital network interface

A Telecommunications Network connection that accepts digitally encoded signals representing analogue voice transmissions or data transmissions.

Note: Examples of digital network interfaces include, but are not limited to DSL, ISDN, 2.048 Mbit/s CAS or CCS, ethernet and digital wireless.

4.2.7 Drum Reference Point (DRP)

A point located at the end of the ear canal, corresponding to the ear-drum position.

4.2.8 Ear Reference Point (ERP)

A virtual point for geometric reference located at the entrance to the listener's ear, traditionally used for calculating telephonometric Loudness Ratings.

4.2.9 Handset

The part of the CE which is held by the user in conversation mode and has the acoustic transmitter and receiver transducers mounted in it.

- 4.2.10 Headset
- The part of the CE which provides the equivalent functionality of the handset but designed to be worn on the head leaving the user's hands free. A headset may use corded or wireless technology.
- 4.2.11 Incoming Call Alert Signal
- A signal which is an indication by CE that an incoming call has arrived from the telecommunications network. The Incoming Call Alert Signal may be audible, visual or by some other means.
- 4.2.12 Industry Based Proprietary Terminal
- Analogue or digital connected terminal, which is intended to operate in association with a CAE and functions as part of the CAE via a local port, for the purpose of voice telephony with the Telecommunications Network and may include both wired and cordless interfaces using proprietary or standards based signalling.
- 4.2.13 Normal volume setting
- The setting of a volume control at which the relevant Loudness Ratings requirements are met.
- 4.2.14 Public Switched Telephone Network (PSTN)
- That part of the Telecommunications Network which enables any customer to establish a connection for voice frequency communication with any other customer either automatically or with operator assistance.
- Note: The PSTN has a nominal transmission bandwidth of 3 kHz.
- 4.2.15 Receive Loudness Rating (RLR)
- Receive loudness rating is a measure of the electro-acoustic characteristic of telephone equipment with respect to the reception of speech signals from a Telecommunications Network.
- 4.2.16 Send Loudness Rating (SLR)
- Send loudness rating is a measure of the electro-acoustic characteristic of the telephone equipment with respect to the transmission of speech signals to a Telecommunications Network.
- 4.2.17 Sidetone Masking Rating (STMR)
- STMR is a measure of the acoustic level perceived by the talker as a result of a portion of the transmitted signal being coupled to the receiver of the same handset or headset by the electrical and air paths and through the bone conduction mechanism in the talker's own body.
- 4.2.18 Telecommunications Network
- Refer to Section 374(1) of the *Telecommunications Act 1997*

4.2.19 Voice Frequency (VF)

Those frequencies in the range of 300 Hz to 3.4 kHz.

4.2.20 VoIP

Voice over Internet Protocol technology encodes voice communications into IP packets for transmission over an IP network in order to provide a telephony service.

4.2.21 Volume Unit (VU)

A unit expressing the signal strength of a complex electric wave of varying amplitude, such as that corresponding to speech or music.

4.2.22 Weighted Terminal Coupling Loss (TCLw)

The (frequency-dependent) coupling loss between the receiving port and the sending port of a terminal due to—

- (a) acoustical coupling at the user interface;
- (b) electrical coupling due to crosstalk in the handset cord or within the electrical circuits; or
- (c) seismic coupling through the mechanical parts of the terminal.

5 REQUIREMENTS

5.1 THIS CLAUSE LEFT BLANK

5.2 Maximum signal level to analogue network line for speech and music

The level of any signals with speech or music characteristics transmitted to line **shall not** exceed 5.0 V peak to peak into a 600 Ω resistive line termination.

Compliance with Clause 5.2 should be checked by using the methods described in Clause 6.3.7.

5.3 Non-electro-acoustic transmission

5.3.1 General

The requirements in Clauses 5.3.2 and 5.3.3 apply to CE that is transmitting to line, speech or music that is not directly generated by an acoustic input.

Note: Examples of CE to which this Clause applies, include but are not limited to, voicemail equipment, telephone answering machines, interconnected private radio base stations and music on hold coupling equipment.

5.3.2 Normal operating level

5.3.2.1 The levels of speech or music, derived from recorded media, line transmission, synthesised speech, synthesised music or other non-acoustic inputs should not be greater than -12 VU and should not be less than -36 VU.

5.3.2.2 Where CE is capable of transmitting composite speech and music signals, the level of the music component should be at least 10 dB lower than the level of the speech component.

Note 1: Due to the characteristics of speech or music signals which can have very high peak values, a special meter and method of reading as described in Appendix A are applicable.

Note 2: The term 'Line Transmission' refers to signals received via a dedicated line from a remote site or location.

Compliance with Clauses 5.3.1 and 5.3.2 should be checked by using the methods described in Clause 6.3.6.

5.3.3 Relative frequency response

The send frequency response of speech or music, derived from pre-recorded media, line transmission, synthesised speech, synthesised music or other non-acoustic inputs should be within the limits of Figure 1 when used in accordance with the CE supplier's instructions.

Note: If automatic level control is fitted, the frequency response may be obtained by recording white noise.

Compliance with Clause 5.3.3 should be checked by using the methods described in Clause 6.3.6.

5.4 Electro-acoustic transmission and reception

5.4.1 General

5.4.1.1 The requirements in Clause 5.4.1 apply to CE that is transmitting to and receiving from a Telecommunications Network, speech that is directly generated by an acoustic input or delivered to an acoustic output.

5.4.1.2 CE with digital network interfaces should support ITU-T Rec. G.711 [8] coding at that interface.

Note 1: This requirement is aligned with ITU-T Rec. P.1010 [15].

Note 2: Carrier/Carriage Service Provider network gateways in the public telecommunications network generally support G.711 codec functionality as a minimum codec functionality. Consequently, it is strongly recommended that CE with digital network interfaces be capable of supporting G.711 codec functionality as a baseline minimum performance. Failure to support G.711 codec functionality may result in the inability to complete call setup to PSTN/ISDN destinations.

5.4.1.3 CE with digital network interfaces supporting ITU-T Rec. G.711 [8] coding at that interface **shall** comply with all applicable clauses in this Standard.

Compliance with Clause 5.4.1.3 should be checked by using the method described in Clauses 6.3.10 and 6.3.11.

5.4.1.4 CE with digital network interfaces using encoding other than ITU-T Rec. G.711 [8] coding at that interface (e.g. low bitrate encoding, speech optimized, etc.)—

- (a) should meet the standard test vectors associated with the codec in use;
- (b) should comply with the Frequency Response, Loudness and Sidetone Masking Ratings requirements of this Standard;
- (c) **shall** comply with the maximum sound pressure level and acoustic shock requirements of this Standard; and
- (d) **shall** comply with other applicable clauses in this Standard.

Note: The use of echo control, voice activity detection, and automatic gain control may influence the test results.

5.4.1.5 CE using any of the Wideband, Super Wideband, or Fullband frequency ranges as defined in ETSI Guide EG 202 518 [18]—

- (a) are exempt from compliance with the Loudness Rating and Sidetone Masking Rating requirements of this Standard for those frequency bands; and
- (b) **shall** comply with the maximum sound pressure level and acoustic shock requirements of this Standard for all frequency bands in which the CE can operate.

5.4.1.6 The performance of CE with acoustic input in addition to the handset or headset should be assessed in accordance to the requirements of Clause 5.4.2.

5.4.1.7 The performance of handsets and headsets intended for use with one or more items of CE **shall** comply with the requirements of Clause 5.4.3, when connected to a representative sample of a suitable telephone instrument.

5.4.2 Customer Equipment without a handset or headset

5.4.2.1 Normal operating level

CE which operates for voice communication exclusively in a hands-free mode, the output level of transmitted signals **shall** be within -6 VU to -18 VU when used in accordance with the CE supplier's instructions.

Note: Compliance with ITU-T Rec. P.340 [14] is recommended.

Compliance with Clause 5.4.2.1 should be checked by using the method described in Clause 6.3.6.

5.4.2.2 Send frequency response

CE which operates for voice communication exclusively in a hands-free mode, the send frequency response to acoustic input **shall** be within the limits of Figure 1 when used in accordance with the CE supplier's instructions.

Note: If automatic level control is fitted, the frequency response may be obtained by recording white noise.

Compliance with Clause 5.4.2 should be checked by using the methods described in Clauses 6.3.3 and 6.3.6.

5.4.3 Customer Equipment incorporating a handset and/or headset

5.4.3.1 Send frequency response

5.4.3.1.1 CE with analogue interfaces which incorporate a—

- (a) handset **shall** comply with the send frequency response limits as shown in Figure 2; or
- (b) headset or cordless handset **shall** comply with the send frequency response limits as shown in Figure 3.

- 5.4.3.1.2 CE with digital network interfaces that has a G.711 codec and incorporates a—
- (a) handset **shall** comply with the send frequency response limits as shown in Figure 4; or
 - (b) headset or cordless handset **shall** comply with the send frequency response limits as shown in Figure 5.

Compliance with Clause 5.4.3.1 should be checked by using the method described in Clause 6.3.3.

5.4.3.2 Receive frequency response

- 5.4.3.2.1 CE with analogue interfaces which incorporates a—
- (a) handset **shall** comply with the receive frequency response limits as shown in Figure 6; or
 - (b) headset or cordless handset **shall** comply with the receive frequency response limits as shown in Figure 7.

- 5.4.3.2.2 CE with digital network interfaces that has a G.711 codec and incorporates a—
- (a) handset **shall** comply with the receive frequency response limits as shown in Figure 6; or
 - (b) headset or cordless handset **shall** comply with the receive frequency response limits as shown in Figure 7.

Compliance with Clause 5.4.3.2 should be checked by using the methods described in Clause 6.3.3.

5.4.3.3 Send and receive Loudness Ratings

- 5.4.3.3.1 CE other than CAE, with analogue network interfaces **shall** comply with the Send Loudness Rating (SLR) and Receive Loudness Rating (RLR) requirements specified in Table 1.

The ranges specified in Table 1 include an allowance for production tolerances for SLR and RLR of telephones but make no allowance for measuring instrument tolerances.

Note: The acceptable send and receive transmission performance for CE is stated in terms of ranges of Loudness Ratings. Short line length performance is also specified to ensure control of the regulation characteristics and to minimise excessively high signal levels and sensitivity to crosstalk.

- 5.4.3.3.2 CE with digital network interfaces that has a G.711 codec **shall** comply with the short term limits for Send Loudness Rating ($11 \text{ dB} > \text{SLR} > 5 \text{ dB}$) and Receive Loudness Rating ($5 \text{ dB} > \text{RLR} > -1 \text{ dB}$) as specified in ITU-T Rec. P.310 [12].

Table 1
Send and receive Loudness Ratings

Cable (mm)	Send Loudness Ratings, SLR (dB)			Receive Loudness Rating, RLR (dB)		
	Line Length			Line Length		
	Short	Average	Limit	Short	Average	Limit
0.40	8 ± 4	8 ± 4	12 ± 4	-4 ± 4	-4 ± 4	0 ± 4
0.64	8 ± 4	8 ± 4	12 ± 4	-4 ± 4	-4 ± 4	0 ± 4

Note: The artificial line circuit representation of limit, average and short line lengths are shown in Figures 12, 13 and 14.

- 5.4.3.3.3 CAE with analogue network interfaces together with their Industry Based Proprietary Terminals **shall** comply with the loudness rating requirements applicable to lines of short length as specified in Table 1.

Compliance with Clause 5.4.3.3 should be checked by using the method described in Clause 6.3.3.

- 5.4.3.4 Sidetone

- 5.4.3.4.1 CE which have analogue network interfaces **shall** comply with the STMR requirements specified in Table 2. The talker sidetone performance is expressed in terms of STMR.

Where two values are shown in the table, the requirement is that the CE **shall** have a measured value of STMR numerically greater than the lesser of the two values.

Table 2
Sidetone masking ratings

Cable (mm)	Load	STMR (dB)		
		Line length – short	Line length – average	Line length – limit
0.4	600 Ω	> 7 or > (SLR0+RLR0+8)	> 7 or > (SLR0+RLR0+8)	> 7 or > (SLR0+RLR0+8)
	Complex	> 7 or > (SLR0+RLR0+8)	> 7 or > (SLR0+RLR0+8)	> 7 or > (SLR0+RLR0+8)
0.64	600 Ω	—	—	> 3 or > (SLR0+RLR0+8)
	Complex	—	—	> 3 or > (SLR0+RLR0+8)

Where: SLR0 = SLR for the particular CE when measured at zero line length.

RLR0 = RLR for the particular CE when measured at zero line length.

Note 1: For short and average line lengths of 0.64 mm cable connections, the STMR requirement is not applicable.

Note 2: CE meeting the SLR, RLR and STMR requirements as specified in Clauses 5.4.3.3 and 5.4.3.4 may not provide satisfactory sidetone performance in all circumstances. The use of switches or straps in the CE to achieve improved sidetone performance is acceptable.

Note 3: The ITU-T recommended target range for STMR is 7 dB to 12 dB for an Analogue Network Interface; refer ITU-T Handbook on Telephonometry [16].

Note 4: Some examples, where above mentioned performance may not be satisfactory, are the following:

- (a) When connected to current limiting feeds and alternate terminations, e.g. some CAE and or Telecommunications Network services.
- (b) At extremes in line length.
- (c) In situations with high ambient noise levels.

5.4.3.4.2 CE with digital network interfaces that has a G.711 codec **shall** comply with the minimum short term limit for Sidetone Masking Rating (STMR > 10 dB) recommended in ITU-T Rec. P.310 [12].

5.4.3.4.3 CAE together with its Industry Based Proprietary Terminals **shall** comply with the STMR for lines of average length.

Compliance with Clauses 5.4.3.1 to 5.4.3.4 should be checked by using the methods described in Clauses 6.3.1, 6.3.2 and 6.3.3 or 6.3.10 and 6.3.11 as appropriate.

5.4.3.5 Weighted Terminal Coupling Loss(TCLw)

For VoIP CE—

- (a) the Weighted Terminal Coupling Loss (TCLw) should exceed the 55 dB limit of ITU-T Rec. P.1010 [15]; and
- (b) echo cancellers should be provided.

5.4.3.6 Howling

5.4.3.6.1 The CE **shall** be stable (i.e. not howling) in the on-line condition when the volume control is at the normal volume setting and with its handset—

- (a) lying on and with the transducers facing a flat glass surface; and
- (b) being returned to its cradle.

Compliance with Clause 5.4.3.6.1 should be checked by using the method described in Clause 6.3.4.

- 5.4.3.6.2 For a cordless CE, the handset **shall** be stable (i.e. not howling) at any distance from its base station in the on-line condition when the volume control is at the normal volume setting.

Compliance with Clause 5.4.3.6.2 should be checked by using the method described in Clause 6.3.4.

- 5.4.3.6.3 For a cordless CE, the handset should be stable (i.e. not howling) at any distance from its base station in the on-line condition when the volume control is at the maximum volume setting.

- 5.4.3.6.4 If a cordless CE has a loud speaking function on the base unit that can be active at the same time that the cordless handset is in use, the user instructions should include a warning notice against bringing the handset close to the base when this feature is in use.

5.4.3.7 Acoustic shock

Acoustic shock is a multi-faceted phenomenon that has a number of contributing factors. A sudden loud sound may cause a person to be startled and can result in significant physical and emotional discomfort. The degree and duration of the effects can depend on factors including, but not limited to—

- (a) the health, stress and emotional state of the person;
- (b) the frequency of the sound; and
- (c) the loudness of the sound.

Note: Devices that comply with the maximum sound pressure levels specified in Clause 5.4.3.8 provide some protection against acoustic shock when compared with devices that do not meet this maximum level. Acoustic shock may, however, still occur in some circumstances regardless of whether the device complies with the maximum level specified in Clause 5.4.3.8. Communications Alliance has published the G616 [5] Guideline on acoustic safety for telephone equipment.

5.4.3.8 Maximum sound pressure level

5.4.3.8.1 General

The maximum RMS and instantaneous output sound pressure levels **shall** be less than the value specified in Table 3 when any user-adjustable receiver volume control is set to maximum when measured—

- (a) using 'RMS', 'Fast' settings of sound level meters as defined in AS IEC 61672-1 [7] or equivalent for short term RMS SPL; or
- (b) using 'Peak', 'Max Hold' settings of sound level meters as defined in AS IEC 61672-1 [7] or equivalent for instantaneous SPL.

Table 3
Maximum sound pressure levels

Equipment	RMS level	Instantaneous level
Handset	120 dB SPL at ERP or equivalent at DRP	123 dB SPL at ERP or 128 dB at DRP
Headset	118 dB SPL at ERP or equivalent at DRP (Note 1)	123 dB SPL at ERP or 128 dB at DRP

Note 1: The figure for the maximum RMS sound pressure level for headsets has been aligned with the proposed international level of 118 dB SPL.

Note 2: The choice of acoustic coupler and artificial ear is to be in accordance with Section 5 of ITU-T Rec. P.57 [9] that describes which of the three types of artificial ear (Type 1, Type 2, or Type 3) should be used for different receiver transducer types. For Wide-band telephony equipment Type 3 acoustic coupler should be used.

Note 3: ITU-T Rec. P.57 [9] also contains data for translating between measurements made at the ear reference point (ERP) (using a Type 1 ear) to equivalent SPLs at the drum reference point (DRP) (using a Type 2 or 3 ear) or vice versa. These conversion data apply only to supra-aural and supra-concha earphones with a high acoustic source impedance. All smaller earphones (insert and intra-concha) and earphones of any size with a low acoustic source impedance, must be measured at the drum reference point with a Type 2 or Type 3 ear.

Note 4: Because the volume simulated by a Type 1 ear includes the concha, measurements made on insert or intra-concha earphones using a Type 1 ear will produce highly misleading (low) sound pressure levels, even if a flat-plate adaptor is added to the Type 1 ear.

Note 5: Conversion between DRP and ERP is to be in accordance with conversion values given in Table 2b of ITU-T Rec. P.57 [9].

Note 6: The upper frequency limit of 8 kHz has been chosen due to measuring equipment limitations and limitations imposed by relevant ITU-T recommendations.

5.4.3.8.2 CE with an analogue PSTN interface

5.4.3.8.2.1 RMS output levels

The maximum output sound pressure level for continuous input voltage **shall** be determined when the source voltage to the CE is varied between 100 mV r.m.s. and 30 V r.m.s. from a 600 Ω source impedance while—

- (a) varying the frequency between 100 Hz and 8 kHz in a swept or continuous manner in accordance with the method detailed in Clause 6.3.5.3;
- (b) varying the frequency in a stepped pulsed manner by applying 500 ms pulses in accordance with the method detailed in Appendix B; and
- (c) with line currents of 20 mA and 80 mA (or maximum attainable line current in the test configuration).

5.4.3.8.2.2 Instantaneous output level

The maximum instantaneous output sound **shall** be determined by subjecting the CE to a single pulse of energy using the circuit illustrated in Figure 18 with line currents of 20 mA and 80 mA (or maximum attainable line current).

5.4.3.8.3 CE with a digital network interface - RMS output levels

The maximum output sound pressure level **shall** be determined by varying a digitally encoded sinusoidal signal with a level—

(a) over the range -9 dBm0 to $+3.14$ dBm0; and

(b) at $+10$ dBm0,

while

(i) varying the frequency between 100 Hz and 8 kHz in a swept or continuous manner in accordance with the method detailed in Clause 6.3.5.4; and

(ii) varying the frequency in a stepped pulsed manner by applying 500 ms pulses in accordance with the method detailed in Appendix B.

Note 1: Measurements at $+10$ dBm0 are required to ensure that a codec is sufficiently overloaded so that it clips the signal (to provide a rectangular waveform, which will have more energy than a sine wave, to the transducer).

Note 2: The level $+3.14$ dBm0 is the sinusoidal maximum signal corresponding to peak digital encoding at the digital interface.

Note 3: The instantaneous output level does not require testing.

5.4.3.8.4 Handsets and/or headsets supplied independently for use with one or more host CE

5.4.3.8.4.1 General

Handsets and/or headsets supplied with detachable amplifiers **shall** be tested with and without the amplifier. The compliance levels, both with and without the amplifier, **shall** be recorded in the report.

Handsets or headsets supplied with dedicated or non-detachable amplifiers **shall** be tested as complete units.

5.4.3.8.4.2 RMS output Levels

The maximum output sound pressure level for continuous input voltage **shall** be determined when the source voltage to the CE is varied between 100 mV and 10 V r.m.s. from a 220 Ω source impedance while—

(a) varying the frequency between 100 Hz and 8 kHz in a swept or continuous manner in accordance with the method detailed in Clause 6.3.5.4 and Appendix B; and

- (b) varying the frequency in a stepped pulsed manner by applying 500 ms pulses in accordance with the method detailed in Clause 6.3.5 and Appendix B.

5.4.3.8.4.3 Instantaneous output level

The maximum instantaneous sound pressure level **shall** be determined when the CE is subjected to a single pulse of energy using the circuit illustrated in Figure 22.

Compliance with Clause 5.4.3.8 should be checked by using the method described in Clause 6.3.5.

5.4.3.9 Audible Incoming Call Alert Signal

5.4.3.9.1 Cordless handset Incoming Call Signal loudness

If an audible Incoming Call Alert Signal is emitted anywhere on the cordless portable telephone or cordless portable part of a cordless telephone system, the maximum sound pressure level **shall not** exceed 120 dB SPL at ERP or equivalent at DRP irrespective of the transducer producing the sound.

5.4.3.9.2 Headset interface Incoming Call Alert Signal

Where an Incoming Call Alert Signal is directed to a physical electrical interface/connector for a headset or earphone, the signal level **shall not** exceed the maximum level for voice signals applied to the same interface when any user-adjustable receiver volume control is set to maximum, minimum and any intermediate value.

Note: Non-voice signals applied to the headset or earphone interface (such as confidence tones, alert signals or DTMF digit signals) should be of a similar electrical level as the voice signals.

5.4.3.9.3 Ring trip on a corded telephone

Where ring trip on a corded telephone is achieved by manual operation of a switch or press button, the audible incoming call signal **shall not** be emitted via the receiver (earpiece) of the telephone.

Compliance with Clause 5.4.3.9 should be checked by inspection and test as specified in Clause 6.3.5 as appropriate.

5.4.3.10 Distortion

5.4.3.10.1 Sending distortion

The total harmonic distortion (summed up to the 5th harmonic) introduced by CE **shall not** be greater than 7 % when measured with an input of -4.7 dBPa, at a loop current of 20 mA.

5.4.3.10.2 Receiving distortion

The total harmonic distortion (summed up to the 5th harmonic) introduced by CE **shall not** be greater than 7 %, when measured with an input signal level of 251 mV r.m.s. at a loop current of 20 mA.

Compliance with Clause 5.4.3.10 should be checked by the method described in Clause 6.3.12 with the user controlled receiving volume control at the nominal setting, if provided.

5.4.3.11 Retention of dangerous objects

The CE **shall not** hold any dangerous objects in the mouthcap or earcap regions unless the CE is provided with a suitable warning notice.

Note: Any warning notice should be legible and placed in a readily visible position, e.g. placed on the CE, on the CE packaging or in the User Instructions.

Compliance with Clause 5.4.3.11 should be checked by using the method described in Clause 6.3.9.

5.5 Acoustic coupling

5.5.1 Acoustic coupling devices **shall not** emit sound pressure levels exceeding 100 dBA SPL.

5.5.2 All acoustic signals emitted by the equipment should be in the range 300 Hz to 3.4 kHz with at least a 12 dB per octave rolloff below 300 Hz and above 3.4 kHz, relative to 100 dB SPL at 3.4 kHz.

5.5.3 Where the equipment generates DTMF signalling frequencies—

- (a) the frequency allocation and tolerance should be in accordance with AS/CA S002 [2]; and
- (b) the sound pressure level difference between low and high group frequency tones should be less than 4 dB, with the sound pressure levels of the lower group frequencies being the lesser.

Compliance with Clause 5.5 should be checked by using the methods described in Clause 6.3.8.

6 TESTING

6.1 General

Compliance with all mandatory requirements applicable to the CE as specified in the requirements clauses is to be verified. This verification may be through direct measurement, modelling and analysis, or inspection.

Methods for demonstrating compliance of CE with requirement clauses specified in this Standard are described in Clauses 6.2 to 6.3. Alternative methods of demonstrating compliance to those described may be used if the risk of passing non-compliant CE is not increased because of increased measurement uncertainty.

CE that provides features by using signal processing techniques that may interfere with the testability of the CE, may incorporate a mechanism for the feature to be disabled during the test, provided that it can be shown that the feature, when active, will not affect the compliance of the CE against the mandatory requirements of this Standard.

CE is to be tested for the following interfaces as appropriate:

- (a) CE with analogue interfaces at the two-wire analogue interface.
- (b) CE with digital interfaces with a test CODEC suited to the CE codec implementation.

6.2 Standard test conditions

6.2.1 Unless this Standard provides otherwise, testing for compliance with this Standard should be conducted at the nominal supply voltage of the CE and within the following ranges of atmospheric conditions:

- (a) An ambient temperature in the range of 15°C to 25°C inclusive.
- (b) A relative humidity in the range of 30% to 75% inclusive.
- (c) An air pressure in the range of 86 kPa to 106 kPa inclusive.

6.2.2 Where elements in a test configuration are variable, the test should be carried out over the indicated range for that element.

6.2.3 Unless indicated elsewhere within this Standard—

- (a) the accuracy level of all measurements should be better than $\pm 2\%$ for voltage and current, $\pm 0.25\%$ for frequency and $\pm 0.5\%$ for time; and
- (b) the tolerance of the nominal 48 V d.c. test source should be ± 0.5 V.

- 6.2.4 Unless indicated elsewhere within this Standard for an individual test, all component values in the test configuration should have a tolerance of—
- (a) 1% for resistance;
 - (b) 1% for capacitance; and
 - (c) -0%, +25% for inductors.
- 6.2.5 The prevailing conditions should be recorded for each test.
- 6.2.6 The handset should be mounted in the Loudness Rating GuardRing Position as defined in Annex C of ITU-T Rec. P.64 [11].
- 6.2.7 All earphones should be tested using the appropriate artificial ear as described in ITU-T Rec. P.57 [9]. For intra-concha measurements, a type 3.3 ear can be used instead of a type 3.1 ear provided that the applicable test method is used.
- 6.2.8 The nature of intra-concha earphones is such that measurements must be performed at the DRP. The conversion information should be replicated in the compliance report.

6.3 Parameters to be tested

- 6.3.1 Send and receive Loudness Ratings measurement
- 6.3.1.1 Handsets
- 6.3.1.1.1 The send and receive Loudness Ratings should be measured using a system conforming with the requirements of ITU-T Rec. P.79 [12].
- 6.3.1.1.2 Calculation of the value of send and receive Loudness Ratings should be in accordance with ITU-T Rec. P.79 [12], formula 2-1, over bands 4 to 17, using $m = 0.175$ and the weighting factors from Table 1 of ITU-T Rec. P.79 [12].
- Note: The weighting factors in ITU-T Rec. P.79 [12] are 0.3 dB smaller than those provided in the original version of the Recommendation in the CCITT Blue Book Vol. V, to allow for the change in loudness of the IRS over the reduced bandwidth.
- 6.3.1.1.3 In the receive loudness rating calculation, the receive sensitivities (S_{je}) measured at each frequency should be corrected by subtracting the leakage correction factors (LE) defined in Table 2 of ITU-T Rec. P.79 [12], unless an advanced artificial ear incorporating a simulated leak is used.
- 6.3.1.1.4 For CE with an analogue network interface, standard test configurations should include—
- (a) feed bridge of 48 V d.c., 400 Ω total resistance and greater than 20 H total inductance;
 - (b) the artificial lines shown in Figures 12, 13, and 14; and

(c) 600 Ω or complex (e.g. TN12) terminations where appropriate.

6.3.1.2 Headsets

6.3.1.2.1 The methods of measuring SLR and RLR of telephones with headsets should be the same as for handsets described in Clause 6.3.1.1, with the exceptions described in ITU-T Rec. P.380 [9].

6.3.1.2.2 Headsets with dual receivers should have the RLR rated by objective measurement of one receiver following the method described in Clause 6.3.1.2.1 for a headset with a single receiver, followed by establishment of a subjective improvement factor from adding the second receiver as described in section 3.4.3.5 of the ITU-T Handbook on Telephonometry [16].

6.3.2 Sidetone masking rating measurement

6.3.2.1 The sidetone masking rating (STMR) should be measured using a system conforming with the requirements of ITU-T Rec. P.79 [12].

6.3.2.2 Calculation of the value of STMR should be in accordance with ITU-T Rec. P.79 [12], formula 2-1, over bands 1 to 20, using $m = 0.225$ and the weighting factors from Table 3 of ITU-T Rec. P.79 [12].

6.3.2.3 For CE with an analogue network interface, standard test configurations should include—

- (a) feed bridge of 48 V d.c., 400 Ω total resistance and greater than 20 H total inductance;
- (b) the artificial lines shown in Figures 12, 13 and 14; and
- (c) 600 Ω or complex terminations where appropriate.

6.3.3 Frequency response measurement

6.3.3.1 The sending and receiving frequency responses should be measured using the appropriate transmission measuring equipment. The equipment configuration should be similar to that of Clause 6.3.1.2 and the circuits shown in Figures 8, 9, 10 and 11 respectively.

6.3.3.2 Measurements should be made at one twelfth-octave intervals as given by the R.40 series preferred numbers in ISO 9614-1 [6] for frequencies from 100 Hz to 4 kHz.

6.3.4 Howling test

For CE with an analogue network interface, the test circuit is shown in Figure 15. The telephone should be tested with total series resistances of 400 Ω and 800 Ω , 48 V d.c. battery feed and 0, 1.6 and 4.2 km of 0.40 mm cable. Under these conditions, the telephone should be stable (not howling) when the handset is placed face down onto the centre of a 250 mm \times 250 mm flat glass surface in both the vertical and horizontal planes and impedance Z set to Complex (as specified in AS/CA S002 [2]) and 600 Ω .

6.3.5 Maximum sound pressure level tests

6.3.5.1 If a volume control can be used with the equipment under test, the volume control should be set to maximum for the tests.

6.3.5.2 When using the 'swept pure tone' method, an initial measurement at the maximum input signal level should be made to determine the frequency producing the highest acoustic pressure. The signal level should then be varied over the specified range at this frequency.

6.3.5.3 CE with an analogue PSTN interface

6.3.5.3.1 RMS Output Levels

The maximum output sound pressure level for a continuous input voltage should be tested with the circuit shown in Figure 16.

6.3.5.3.2 Instantaneous Output Level

The maximum instantaneous output sound pressure level should be tested with the circuit shown in Figure 18 by switching from pole A to pole B after the capacitor has been charged to 100 V. The test will be repeated by switching from pole B to pole A. A switch with minimum contact bounce should be used to ensure a single consistent pulse is generated.

6.3.5.4 CE with a digital network interface - RMS Output Levels

The maximum output sound pressure level should be tested with the circuit shown in Figure 17. When the input to the precision codec is sinusoidal, it must be at a high enough level to ensure that a rectangular wave shape is obtained on overload when digital encoding has been performed. Alternatively a rectangular wave shape signal may be applied to the precision codec analogue input.

Note: There is no test required for instantaneous output levels.

6.3.5.5 Handsets and/or headsets, supplied independently, for use with one or more host CE.

6.3.5.5.1 General

Handsets and/or headsets supplied with detachable amplifiers are to be tested with and without the amplifier.

Handsets or headsets supplied with dedicated or non-detachable amplifiers are to be tested for compliance as complete units.

6.3.5.5.2 RMS Output Levels

The maximum output sound pressure level for continuous input voltage should be tested with the circuit shown in Figure 21.

6.3.5.5.3 Instantaneous Output Level

The maximum instantaneous output sound pressure level should be tested with the circuit shown in Figure 22, by switching from pole A to pole B after the capacitor has been charged to 100 V. The test will be repeated by switching from pole B to pole A. A switch with minimum contact bounce should be used to ensure a single consistent pulse is generated.

6.3.5.5.4 Audible Incoming Call Alert Signal

The sound pressure level of the audible Incoming Call Alert Signal should be measured using an artificial ear described in Clause 6.2.7 pressed against the earpiece transducer.

6.3.6 Test on transmission of speech and music

6.3.6.1 For CE with an analogue network interface, the Test Circuit should be as shown in Figure 19. Where a VU meter is required, its characteristics should be in accordance with that described in Appendix A.

6.3.6.2 Acoustic input other than from a handset should be measured for transmission level and frequency response using an 'artificial voice' as the sound source. This is set to produce a continuous uniform pressure spectrum of 200 Hz to 5 kHz at a free field sound pressure level of 94 dB (reference pressure = 20 μ Pa) measured at the Mouth Reference Point (MRP), a distance of 25 mm from the virtual source.

6.3.6.3 The position of the virtual sound source relative to the CE under test should be in accordance with the CE supplier's operating instructions.

For CE which operates for voice communication exclusively in a hands-free mode, when no CE supplier's operating instructions are provided, the Handsfree Reference Point will be in accordance with ITU-T Rec. P.340 [14] (at a point located on the axis of the artificial mouth at 50 cm from the lip ring).

6.3.6.4 Electrical input from music or live source should be measured for transmission level according to the manufacturer's operating instructions. The frequency response should be measured by substituting the music source by an appropriate white noise source or swept signal source.

6.3.6.5 Internally generated messages should be measured for transmission level only for the duration of the message or over one minute periods, whichever is shorter.

6.3.6.6 For CE which requires speech or discontinuous signals and not constant or continuous signals for testing, the equipment supplier should provide the required test method.

6.3.7 Maximum speech and music level to line

For CE with an analogue network interface, the Test Circuit should be as shown in Figure 19. The level and frequency of the acoustic or electrical input should be varied and the output monitored for maximum peak to peak output signal to line.

6.3.8 Acoustic coupling test

The frequency and sound pressure level of acoustic couplers should be measured using a sound pressure level measurement set and a condenser microphone (B & K Type 4144 or similar). The microphone mounting should be as shown in Figure 20. Alternatively, a coupler plate as specified in Figure A.1 of I-ETS 300 380 [19] may be used.

6.3.9 Retention of small objects

6.3.9.1 The handset or equivalent, complete with transducers fitted, should be positioned during the test such that a plane tangent to the earcap or mouthcap (whichever is being tested) is horizontal with the openings of the transducers facing upwards.

6.3.9.2 Small unmagnetised ferromagnetic common items such as pins and type 26/6 loose staples should be placed randomly over the earcap/mouthcap regions. The maximum size of the pins should be 20 mm length and 0.25 mm shaft diameter. When the handset or equivalent is rotated so that the transducer openings face downwards, no items should be magnetically retained in the earcap or mouthcap regions.

6.3.10 Measurement of SLR and RLR of CE with a digital network interface

The measurement of SLR and RLR should be performed with a test codec in the test configurations of Figures 9 and 11. Test methods should be follow those described for handsets in Clause 6.3.1.1 or headsets in Clause 6.3.1.2 as appropriate.

6.3.11 Measurement of STMR of CE with a digital network interface

Test methods should follow those described for analogue handsets in Clause 6.3.2.

6.3.12 G.711 interface

CE with a digital interface can be tested by a direct injection of G.711 encoded signals (as shown in Figures 9 and 11), or by the use of a G.711 gateway. The gateway must be qualified to ensure that an analogue input results in the same level digital output.

6.3.13 Distortion measurements for CE with a handset and/or headset

Sending distortion should be checked by the test described in Subclause 4.2.4.1 of I-ETS 300 480 [20] with the feed resistance adjusted to produce a loop current of 20 mA.

Receiving distortion should be checked by the test described in Subclause 4.2.4.2 of I-ETS 300 480 [20] with the feed resistance adjusted to produce a loop current of 20 mA.

6.3.14 Measurements of Weighted Terminal Coupling Loss (TCLw)

ANSI TIA/EIA-810-A [21] contains methods and guidance for TCLw measurements.

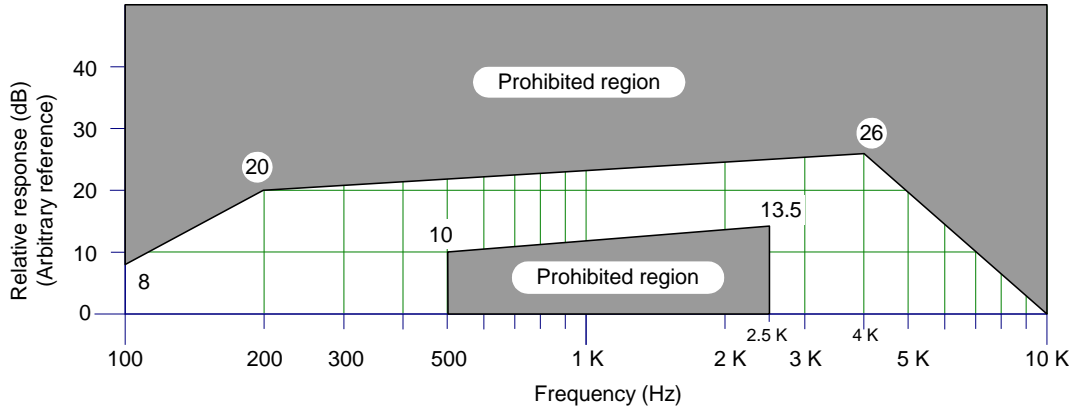

Figure 1

**Send frequency response mask –
Acoustic input other than from handset or headset**

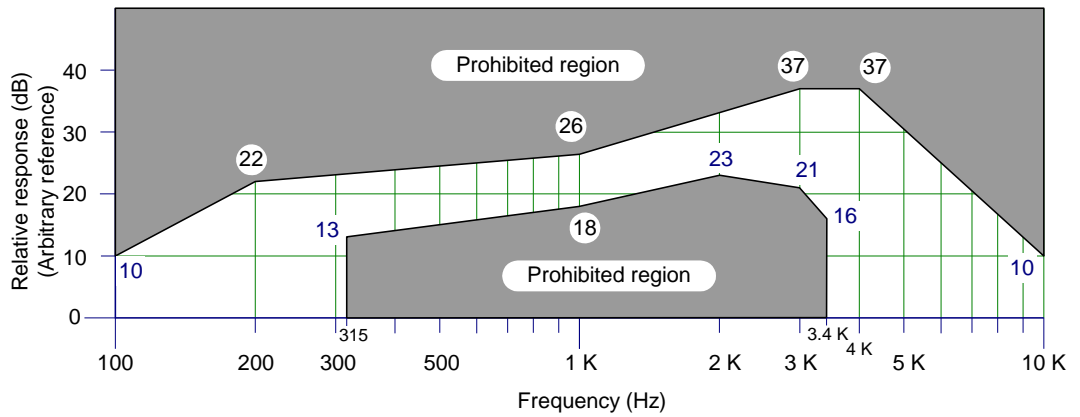

Figure 2

**Send frequency response mask for handset
(Analogue Interface – 1.6 km of 0.40 mm copper cable)**

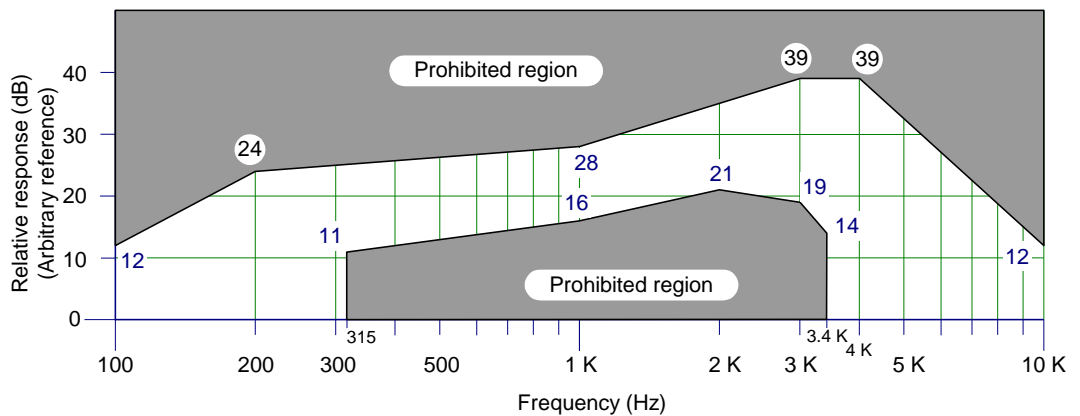

Figure 3

**Send frequency response mask for headset
(Analogue Interface – 1.6 km of 0.40 mm copper cable)**

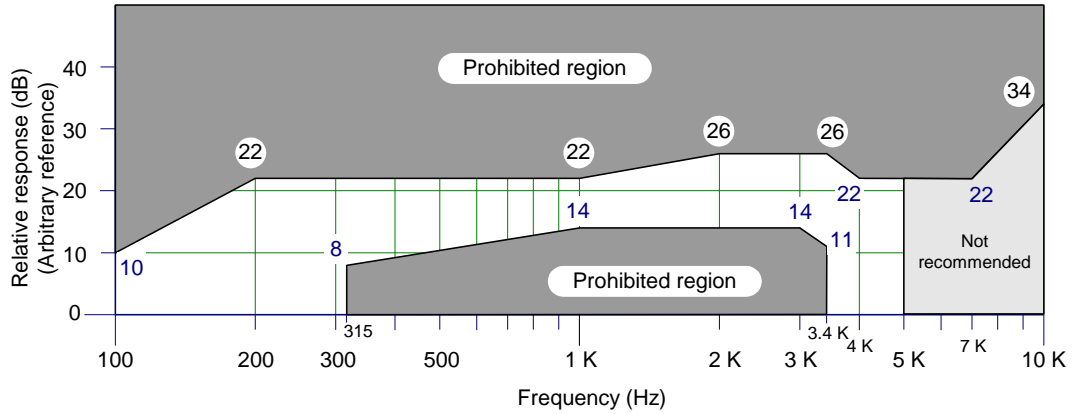

Figure 4

Send frequency response mask for handset – Digital interface

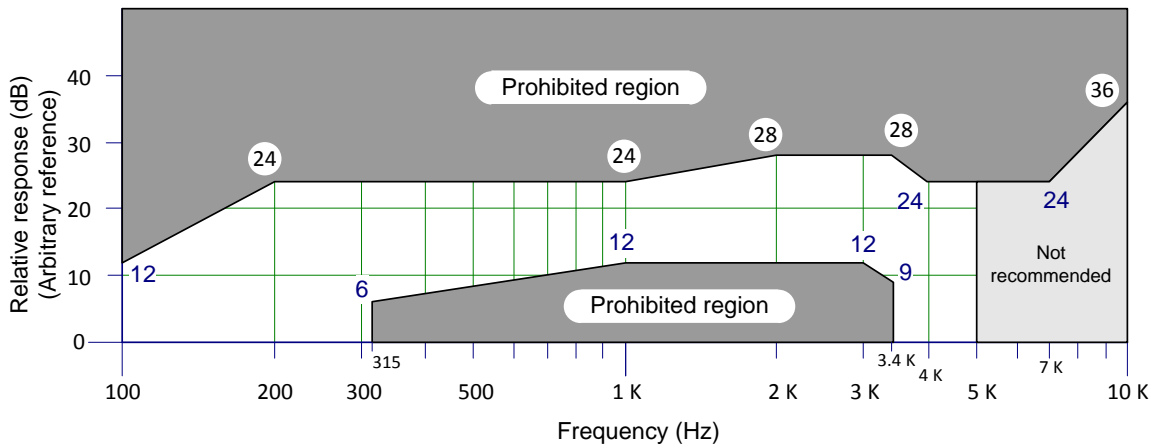

Figure 5

Send frequency response mask for headset – Digital interface

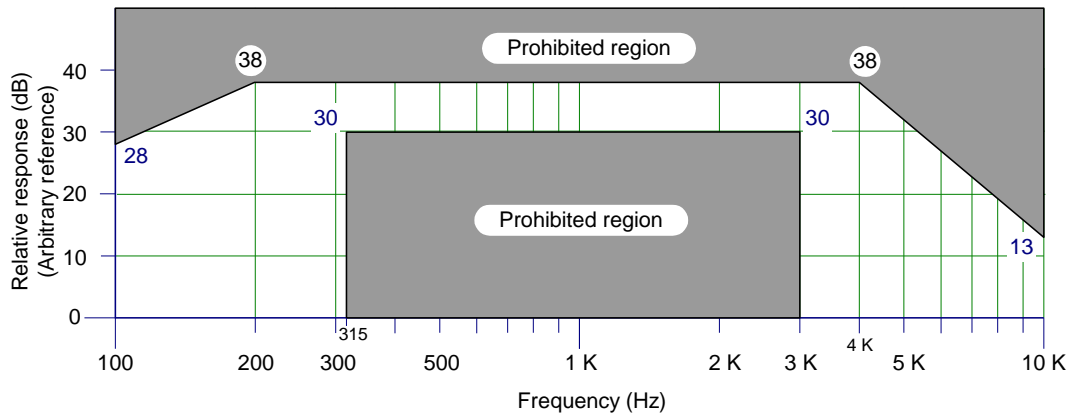

Figure 6

**Receive frequency response mask for handset –
Analogue Interface (1.6 km of 0.40 mm copper cable)
and**

Receive frequency response mask for handset – Digital interface

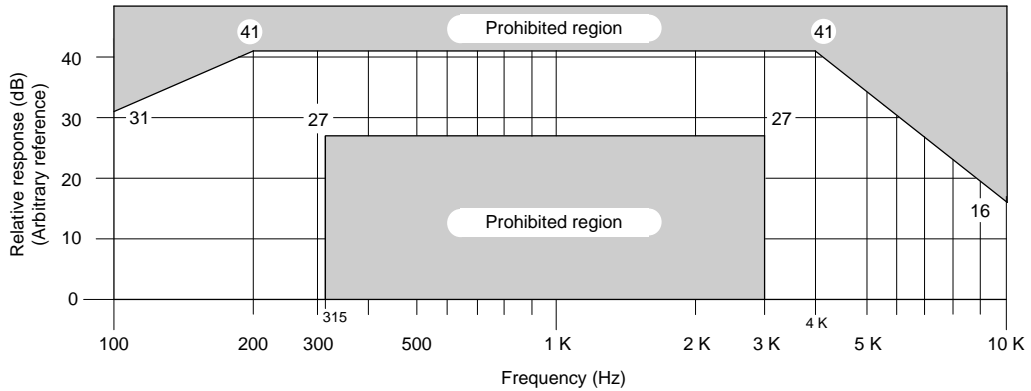

Figure 7

**Receive frequency response mask –
Analogue Interface (1.6 km of 0.40 mm copper cable) and
Receive frequency response mask for headset – Digital interface**

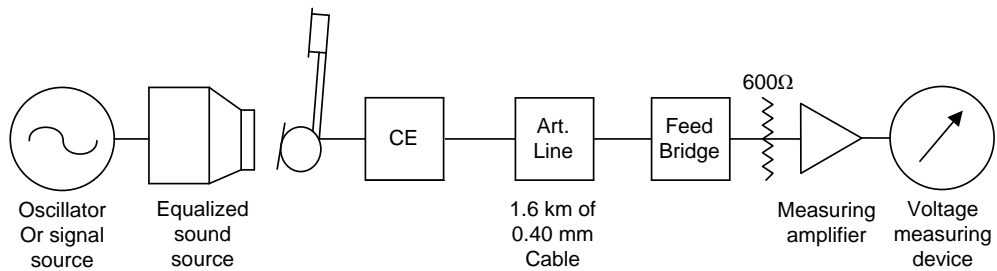

Figure 8

Schematic for sending frequency response test

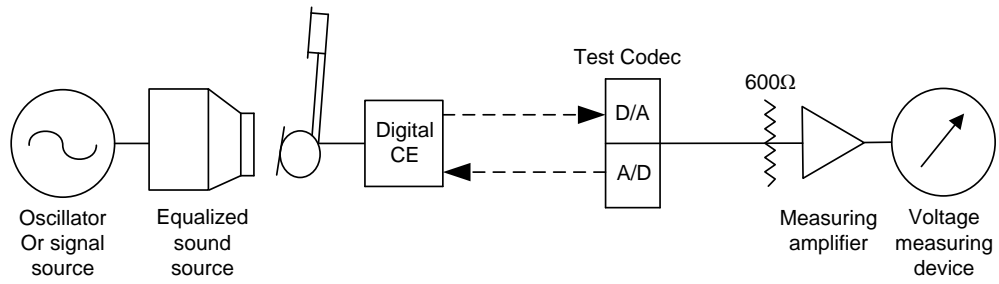

Figure 9

Schematic for sending frequency response test – Digital telephone

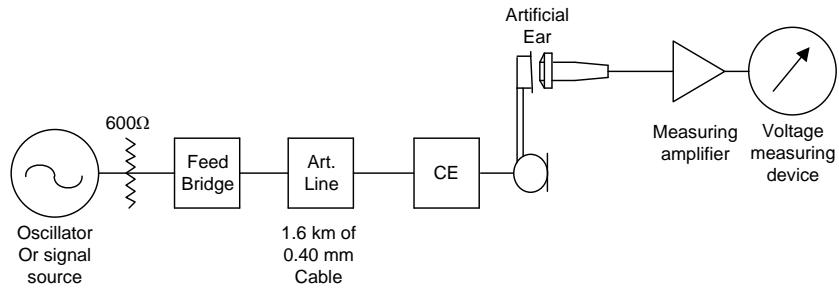

Figure 10

Schematic for receiving frequency response

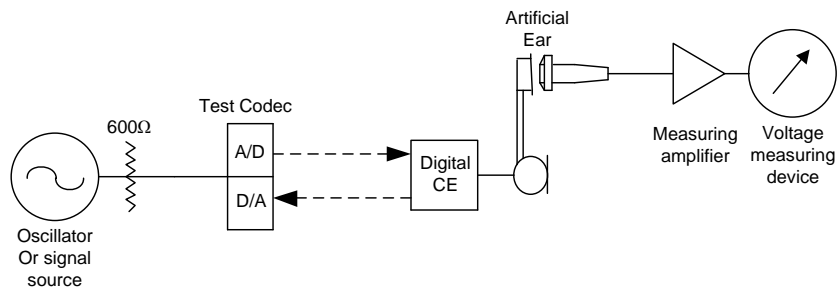

Figure 11

Schematic for receiving frequency response test – Digital telephone

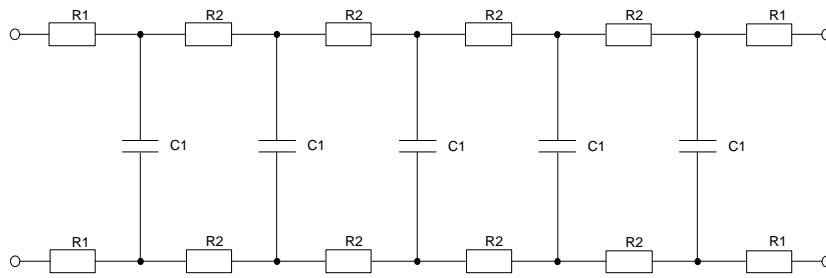

Figure 12

Artificial line – Limit length (4.2 km of 0.40 mm cable or 7.0 km of 0.64 mm cable)

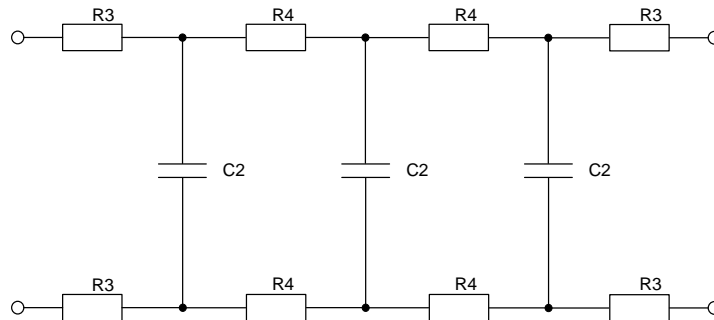

Figure 13

Artificial line – Average length (1.6 km of 0.40 mm cable or 2.5 km of 0.64 mm cable)

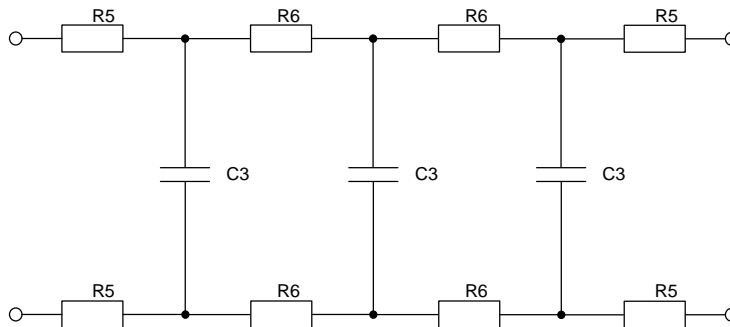

Figure 14

Artificial line – Short length (0.5 km of 0.40 mm cable or 0.5 km of 0.64 mm cable)

Cable Size (mm)	R1 (Ω)	R2 (Ω)	R3 (Ω)	R4 (Ω)	R5 (Ω)	R6 (Ω)	C1 (nF)	C2 (nF)	C3 (nF)
0.40	56.1	112.2	35.6	71.3	11.1	22.3	38.0	24.0	7.5
0.64	37.5	75.0	22.5	45.0	4.5	9.0	63.0	38.0	7.5

Tolerance $\pm 2\%$

Component values for Figures 12, 13 and 14

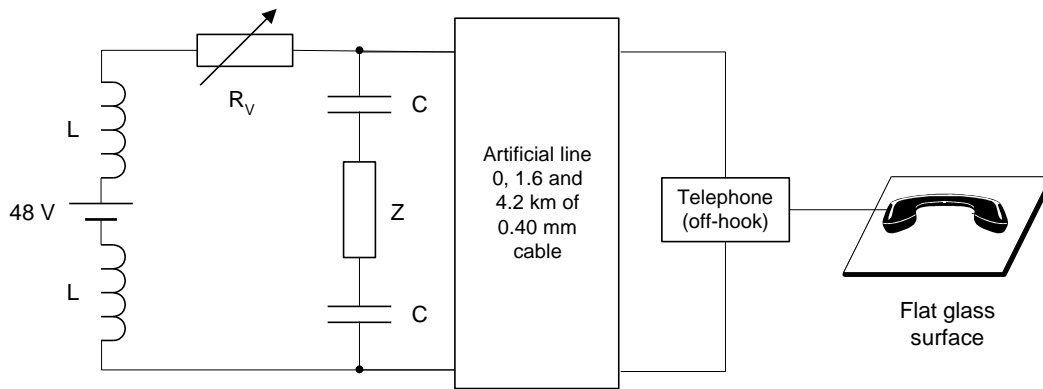

Note 1: All measurements to accuracy better than:
 ± 2% voltage and current
 ± 0.5% time
 ± 0.25% frequency
 ± 0.2 dB power level

Note 2: The battery should be replaced by a shorting link if the DUT does not draw loop current from the line.

$L \geq 10 \text{ H}$ up to 125 mA d.c. over the range
 100 Hz to 4 kHz
 $R_v = 400 \Omega$ to 800 Ω (includes resistance of 2L)
 $C = 100 \mu\text{F}$
 $Z = 600 \Omega$ or Complex

Figure 15
Test circuit for howling

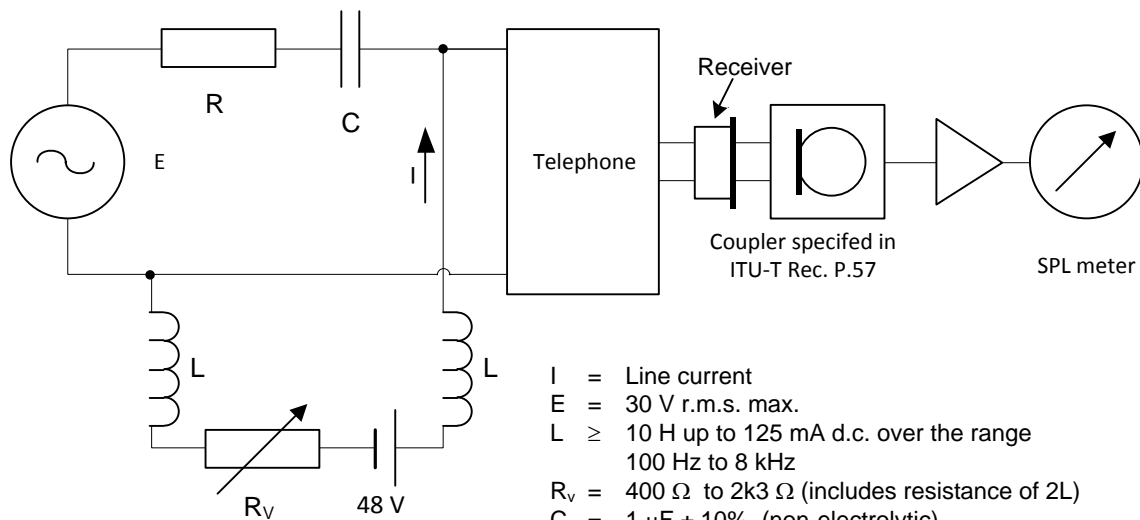

Note 1: All measurements to accuracy better than:
 ± 2% voltage and current
 ± 0.5% time
 ± 0.25% frequency
 ± 0.2 dB power level

Note 2: Oscillator frequency set for peak receive response

$I =$ Line current
 $E = 30 \text{ V r.m.s. max.}$
 $L \geq 10 \text{ H}$ up to 125 mA d.c. over the range
 100 Hz to 8 kHz
 $R_v = 400 \Omega$ to 2k3 Ω (includes resistance of 2L)
 $C = 1 \mu\text{F} \pm 10\%$ (non-electrolytic)
 $R = 600 \Omega \pm 1\%$

Figure 16
Test circuit for continuous input – CE with analogue interface

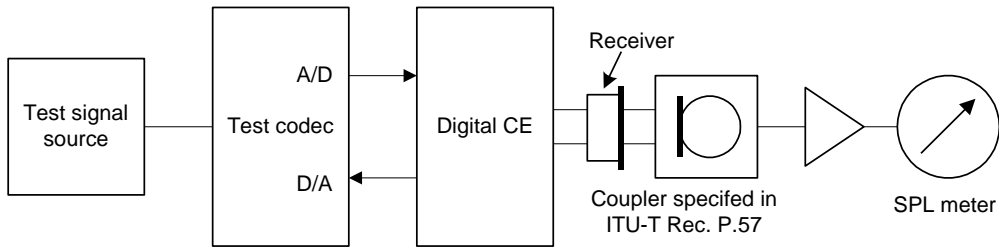

Figure 17

Test circuit for continuous input – CE with digital interface

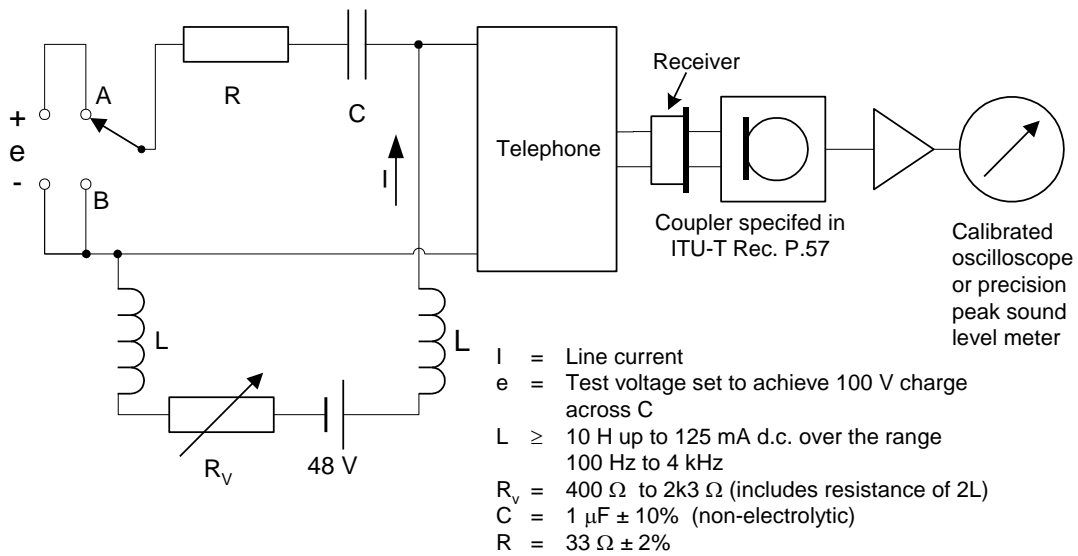
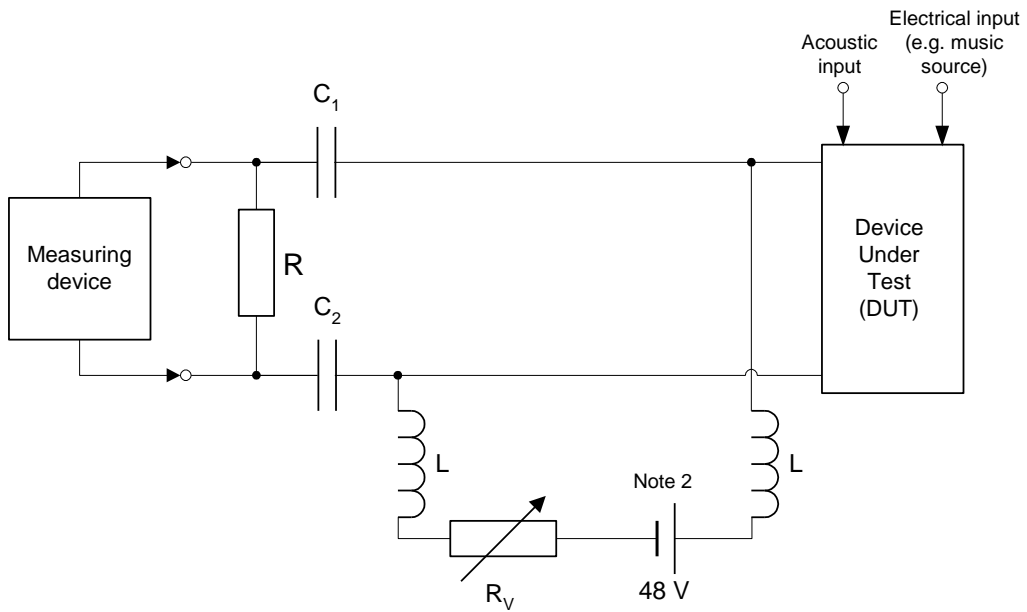

Figure 18

Test circuit for pulse input



Note 1: All measurements to accuracy better than:
± 2% voltage and current
± 0.5% time
± 0.25% frequency
± 0.2 dB power level

Note 2: The battery should be replaced by a shorting link if the DUT does not draw loop current from the line.

$L \geq 10 \text{ H}$ up to 125 mA d.c. over the range 100 Hz to 4 kHz
 $R = 600 \Omega \pm 1\%$
 $R_v = 400 \Omega$ to 2k3 Ω (includes resistance of 2L)
 $C_1, C_2 \geq 100 \mu\text{F}$

Figure 19

Test circuit for transmission level and frequency response

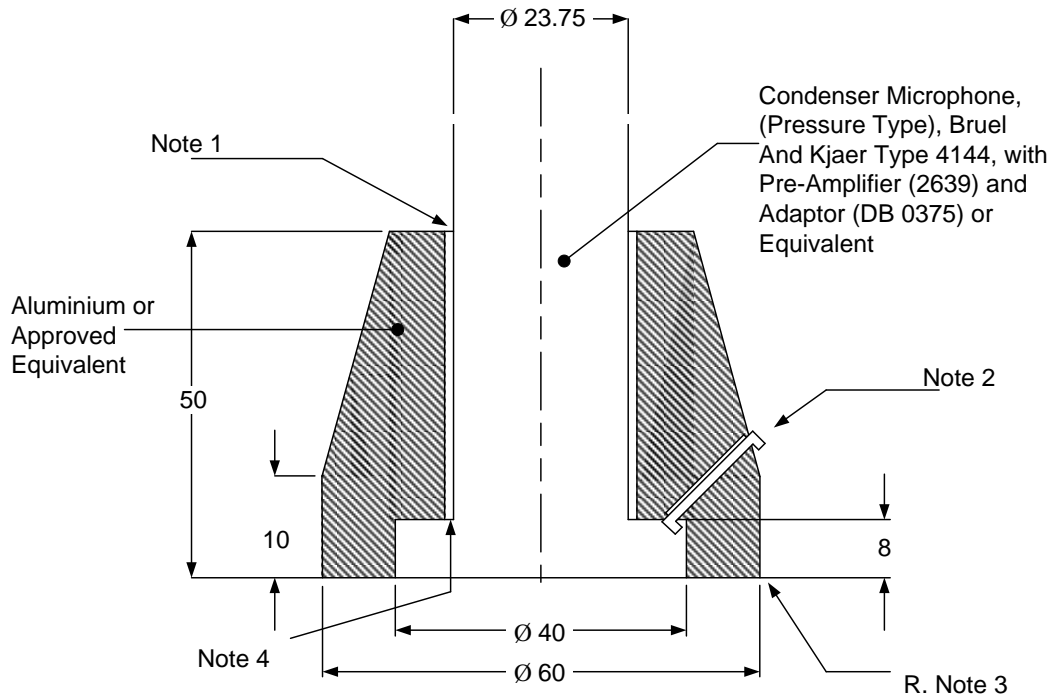

Note 1: Line with felt, approximately 2mm thick to give tight sliding fit on microphone housing.

Note 2: Pressure leak, 0.60 mm diameter hole with 0.50 mm diameter wire insert bent over at ends.

Note 3: All corner radii 1mm.

Note 4: Microphone to be located with its lower edge of its diaphragm flush with top cavity in the position shown

Figure 20

Test equipment for testing the acoustic sound pressure level of acoustically coupled devices

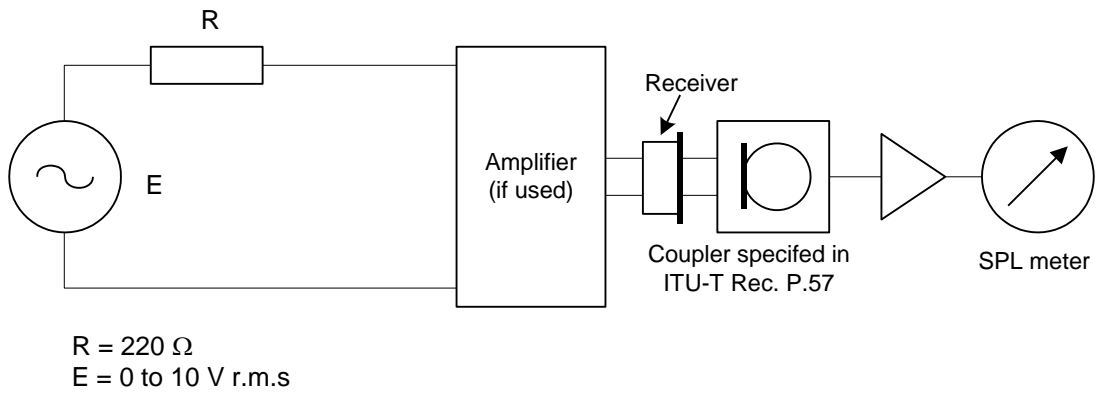

Figure 21

Test circuit for independently supplied handset/headset

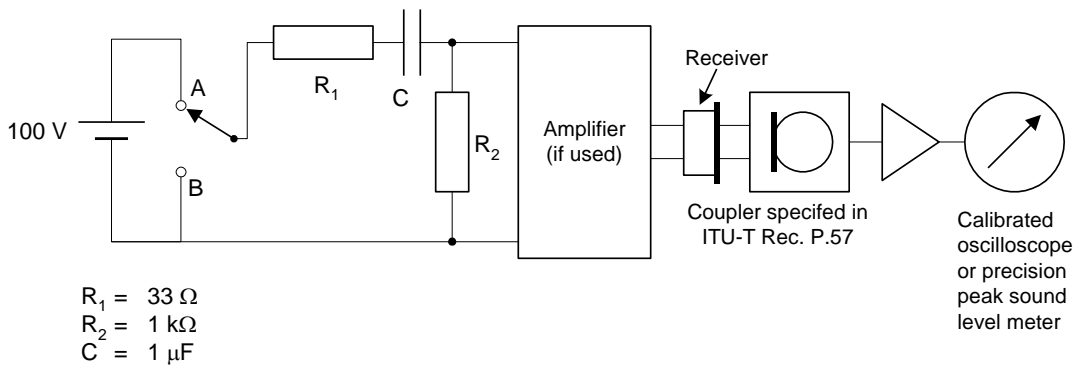

Figure 22

Test circuit for pulse input for independently supplied handset/headset

APPENDIX A

A Volume Unit Indicator

Volume is measured by means of a volume indicator. This device should conform to the following specifications and should be used in the manner described in Clauses A.1 to A.9.

A1 Component parts

A volume indicator consists of at least two parts:

- (a) A meter.
- (b) An attenuator.

A2 Dynamic characteristics

If a sinusoidal voltage between 35 Hz and 10 kHz, of such amplitude as to give reference deflection (0 VU) under steady-state conditions, is suddenly applied, the meter point should reach 99% of reference deflection in $0.3 \text{ s} \pm 10\%$, and should then overswing reference deflection by at least 1% and not more than 1.5%. The time required for the meter pointer to reach its position of rest on the removal of the sinusoidal voltage should not be greatly different from the time of response.

A3 Response versus frequency characteristic

The response of the volume meter to steady-state sinusoidal signals should not depart from that at 1 kHz by more than 0.2 dB between 35 Hz and 10 kHz, nor more than 0.5 dB between 25 Hz and 16 kHz.

A4 Response to complex waves

The response to complex waves of such amplitude as to give reference deflection, when read as described below, should be that equivalent to the response with a DC meter and a rectifier, the exponent of whose characteristics is 1.20 ± 0.2 .

A5 Reversibility

The response when measuring asymmetrical waves must be independent of the connection polarity of the volume indicator. Such a characteristic may be obtained by the use of a DC meter in conjunction with a full-wave rectifier.

A6 Graduation of meter scale

The point of reference deflection should be marked 0 VU. The remainder of the scale should be graduated in VU above and below reference deflection.

A7 Attenuator

The attenuator is normally adjustable and its control should be graduated in volume units.

A8 Calibration

The measuring instrument of a correctly calibrated volume indicator with its attenuator set at 0 VU will give reference deflection when connected to a source of a sinusoidal voltage adjusted to develop 1 mW in a resistance of 600 Ω (0 dBm), or with the attenuator set at n VU when the calibrating voltage is adjusted to develop a power n dB above 1 mW in a resistance of 600 Ω (n dBm).

A9 Method of reading volume indicator

A.9.1 Duration of Measurement

The reading of the measuring instrument is determined by the greatest deflections occurring in a period of about a minute for program waves, or a shorter period (e.g. 5 seconds to 10 seconds) for message telephone speech waves, excluding not more than one or two occasional deflections of unusual amplitude.

A.9.2 Measurement relative to reference point

The volume indicator is usually connected across the circuit at a point where the impedance is 600 Ω and the attenuator is adjusted until the deflections, read as described above, just reach the scale point corresponding to reference deflection. The volume in VU is determined by the markings on the attenuator at the setting thus obtained. If for any reason the deflections reach some other scale point than that corresponding to reference deflection, the volume is given by the algebraic addition of the attenuator setting and the actual deflection as read on the meter scale.

A.9.3 Correction to volume for impedance difference

When the impedance of the circuit at the point at which the instrument is connected differs from 600 Ω , the volume indicated must be corrected to correspond to this difference in impedance by the following relationship:

$$\text{Correction (VU)} = 10 \times \log_{10} \left(\frac{600}{|Z|} \right)$$

where: $|Z|$ = magnitude of actual impedance.

Note 1: The correction is to be added algebraically.

Note 2: The above ITU-T definition makes no statement on the sensitivity of the actual meter movement (where used). For most practical meter movements the required dynamic characteristics can only be met by using a resistor in series with the meter movement and thus effectively reducing its sensitivity. Typically the resistor chosen results in a drop of 4 dB sensitivity. This is compensated for by the scale reading of the associated attenuator such that 0.775 V r.m.s. represents a signal of 0 VU.

APPENDIX B

B Stepped Pulsed Stimuli For Time Dependent Limiting Test

B1 Introduction

This Appendix defines the test parameters required for the pulsed tone measurement method as specified in Clause 6.3.5.4 for products that may incorporate a form of AGC (automatic gain control).

The recommended step test parameters are:

- (a) Frequency steps to be in one-third octave intervals over the frequency range from 100 Hz to 900 Hz, one-twelfth octave intervals from 900 Hz to 3 kHz and one-sixth octave intervals from 3 kHz to 8 kHz.
- (b) Tone duration: 500 ms
- (c) Tone off time between steps: 3 seconds
- (d) Level step size:
 - a. Analogue PSTN interface graduated between 100 mV and 30 V r.m.s.
 - b. Digital interface 2 dB
 - c. Handsets/headsets graduated between 100 mV and 10 V r.m.s.

Note 1: This method is chosen to ensure that an Automatic Gain Control system will recover in between test steps and ensure that the CE remains in a high gain mode throughout the test.

Note 2: Refer to relevant Tables B1 to B5 for actual step values.

Note 3: A compact disk (CD) has been produced to assist in providing the stepped pulse stimuli in order to ensure repeatable test procedures. This is provided free of additional charge with printed hardcopies of this Standard. The printed hardcopy of this Standard and the compact disk may be obtained from SAI Global, GPO Box 5420, Sydney NSW 2001 or via www.saiglobal.com.

There are three versions of the test sequence on the CD to suit the requirements of—

- (a) an analogue telephone product with a POTS connection;
- (b) a digital product e.g. ISDN or digital system integral telephone; and
- (c) a headset that can replace the handset of either of the above.

For each of the above a specific test sequence has been provided on the CD. In each case, a series of tone pulses is provided at specific frequencies beginning at a relative low level and increasing over a number of steps up to the maximum level required for the product.

The CD is recorded as a two channel recording with the test sequence recorded on channel 1 with voice announcements on channel 2 to advise and prompt the test officer as to which test is being run.

When performing the test, channel 1 is to be connected to a power amplifier capable of driving the required level to the test object while channel 2 is to be connected to a monitor amplifier and speaker (or headphone) at a suitable listening level.

A ten second alignment tone is provided at the beginning of each sequence to set up the amplifier gain to the correct level. This is followed by ten seconds of silence before the test sequence continues beginning at the minimum level.

This sequence is repeated at each of forty specified test frequencies over the voice band.

B2 Test frequency list

The following frequency list is considered to adequately test a product over the voice band, particularly covering the frequencies where an acoustic shock is most likely to be induced, i.e. greater than 1 kHz.

Table B1
Test frequency list

Test group	Frequency (Hz)	Test group	Frequency (Hz)
1	100	21	1728
2	125	22	1830
3	160	23	1939
4	200	24	2053
5	250	25	2175
6	315	26	2304
7	410	27	2441
8	516	28	2585
9	649	29	2738
10	818	30	2901
11	972	31	3073
12	1029	32	3255
13	1090	33	3652
14	1155	34	4340
15	1223	35	4597
16	1296	36	5158
17	1372	37	5788
18	1454	38	6494
19	1540	39	7286
20	1631	40	8175

B3 Telephone products tracks

The test sequences for analogue telephone, digital and headset products are listed in Tables B3, B4 and B5 respectively, with the alignment tone each of these test sequences specified in Table B2 below. The maximum SPL during each of the sequences is to be recorded for both line currents.

Table B2
Alignment tones

Products track	Frequency (Hz)	Duration (s)	Voice prompt	Action
Analogue telephone	1040	10	'Alignment tone'	Adjust for 30 V r.m.s. at source
Digital	1040	10	'Alignment tone'	Adjust for +3.0 dBm0 at test codec
Headset	1040	10	'Alignment tone'	Adjust for 10 V r.m.s. at source

Table B3
Analogue telephone products track test sequence

Test Group 1		
Voltage (V)	Duration (s)	Voice announcement
0	10	'100 Hz 100 mV'
0.1	0.5	
0	3	'100 Hz 300 mV'
0.3	0.5	
0	3	'100 Hz 1 volt'
1	0.5	
0	3	'100 Hz 3 volts'
3	0.5	
0	3	'100 Hz 10 volts'
10	0.5	
0	3	'100 Hz 20 volts'
20	0.5	
0	3	'100 Hz 30 volts'
30	0.5	

Test Groups 2 to 39			
Group	Voltage (V)	Duration (s)	Voice announcement
	0	3	'125 Hz 100 mV'
	0.1	0.5	
<i>This sequence repeated for</i>			
2, 21	125		1728
3, 22	160		1830
4, 23	200		1939
5, 24	250		2053
6, 25	315		2175
7, 26	410		2304
8, 27	516		2441
9, 28	649		2585
10, 29	818		2738
11, 30	972		2901
12, 31	1029		3073
13, 32	1090		3255
14, 33	1155		3652
15, 34	1223		4340
16, 35	1296		4597
17, 36	1372		5158
18, 37	1454		5788
19, 38	1540		6494
20, 39	1631		7286
	0	3	'7286 Hz 30 volts'
	30	0.5	

Test Group 40		
Voltage (V)	Duration (s)	Voice announcement
0	10	'8175 Hz 100 mV'
0.1	0.5	
0	0	'8175 Hz 100 mV'
0.3	0.5	
0	3	'8175 Hz 1 volt'
1	0.5	
0	3	'8175 Hz 3 volts'
3	0.5	
0	3	'8175 Hz 10 volts'
10	0.5	
0	3	'8175 Hz 20 volts'
20	0.5	
0	3	'8175 Hz 30 volts'
30	0.5	

Table B4
Digital products track test sequence

Test Group 1		
Level	Duration (s)	Voice announcement
0 V	10	'100 Hz -9 dBm0'
-9 dB	0.5	
0 V	3	'100 Hz -7 dBm0'
-7 dB	0.5	
0 V	3	'100 Hz -5 dBm0'
-5 dB	0.5	
0 V	3	'100 Hz -3 dBm0'
-3 dB	0.5	
0 V	3	'100 Hz -1 dBm0'
-1 dB	0.5	
0 V	3	'100 Hz +1 dBm0'
+1 dB	0.5	
0 V	3	'100 Hz +3 dBm0'
+3 dB	0.5	
0 V	3	'100 Hz +10 dBm0'
+10 dB	0.5	

Test Groups 2 to 39			
Group	Level	Duration (s)	Voice announcement
	0 V	3	'125 Hz -9 dBm0'
	-9 dB	0.5	
<i>This sequence repeated for</i>			
2, 21		125	1728
3, 22		160	1830
4, 23		200	1939
5, 24		250	2053
6, 25		315	2175
7, 26		410	2304
8, 27		516	2441
9, 28		649	2585
10, 29		818	2738
11, 30		972	2901
12, 31		1029	3073
13, 32		1090	3255
14, 33		1155	3652
15, 34		1223	4340
16, 35		1296	4597
17, 36		1372	5158
18, 37		1454	5788
19, 38		1540	6494
20, 39		1631	7286
	0 V	3	'7286 Hz +10 dBm0'
	+10 dB	0.5	

Test Group 40		
Level	Duration (s)	Voice announcement
0 V	3	'8175 Hz -9 dBm0'
-9 dB	0.5	
0 V	3	'8175 Hz -7 dBm0'
-7 dB	0.5	
0 V	3	'8175 Hz -5 dBm0'
-5 dB	0.5	
0 V	3	'8175 Hz -3 dBm0'
-3 dB	0.5	
0 V	3	'8175 Hz -1 dBm0'
-1 dB	0.5	
0 V	3	'8175 Hz +1 dBm0'
+1 dB	0.5	
0 V	3	'8175 Hz +3 dBm0'
+3 dB	0.5	
0 V	3	'8175 Hz +10 dBm0'
+10 dB	0.5	

Note: The +10 dBm0 signal is provided to ensure that the codec is overloaded and will clip the signal so that it is close to a square wave which will provide more energy than a sine wave.

Table B5
Headset products track test sequence

Test Group 1		
Voltage (V)	Duration (s)	Voice announcement
0	10	'100 Hz 100 mV'
0.1	0.5	
0	3	'100 Hz 300 mV'
0.3	0.5	
0	3	'100 Hz 600 mV'
0.6	0.5	
0	3	'100 Hz 1 volt'
1	0.5	
0	3	'100 Hz 3 volts'
3	0.5	
0	3	'100 Hz 6 volts'
6	0.5	
0	3	'100 Hz 10 volts'
10	0.5	

Test Groups 2 to 39			
Group	Voltage (V)	Duration (s)	Voice announcement
	0	3	'125 Hz 100 mV'
	0.1	0.5	
<i>This sequence repeated for</i>			
2, 21	125		1728
3, 22	160		1830
4, 23	200		1939
5, 24	250		2053
6, 25	315		2175
7, 26	410		2304
8, 27	516		2441
9, 28	649		2585
10, 29	818		2738
11, 30	972		2901
12, 31	1029		3073
13, 32	1090		3255
14, 33	1155		3652
15, 34	1223		4340
16, 35	1296		4597
17, 36	1372		5158
18, 37	1454		5788
19, 38	1540		6494
20, 39	1631		7286
	0	3	'7286 Hz 10 volts'
	10	0.5	

Test Group 40		
Voltage (V)	Duration (s)	Voice announcement
0	3	'8175 Hz 100 mV'
0.1	0.5	
0	3	'8175 Hz 300 mV'
0.3	0.5	
0	3	'8175 Hz 600 mV'
0.6	0.5	
0	3	'8175 Hz 1 volt'
1	0.5	
0	3	'8175 Hz 3 volts'
3	0.5	
0	3	'8175 Hz 6 volts'
6	0.5	
0	3	'8175 Hz 10 volts'
10	0.5	

NOTES

PARTICIPANTS

The Working Committee responsible for the revisions made to this Standard consisted of the following organisations:

Organisation	Membership
Cisco Systems	Voting
Comtest Laboratories	Voting
Jabra	Voting
Primus Telecoms	Voting
Trillium Technology	Voting
Communications Alliance	Non-voting

This Working Committee was chaired by Malcolm Garnham of Trillium Technology. Mike Johns of Communications Alliance Ltd provided project management support.

Communications Alliance was formed in 2006 to provide a unified voice for the Australian communications industry and to lead it into the next generation of converging networks, technologies and services.

In pursuing its goals, Communications Alliance offers a forum for the industry to make coherent and constructive contributions to policy development and debate.

Communications Alliance seeks to facilitate open, effective and ethical competition between service providers while ensuring efficient, safe operation of networks, the provision of innovative services and the enhancement of consumer outcomes.

It is committed to the achievement of the policy objective of the *Telecommunications Act 1997* - the greatest practicable use of industry self-regulation without imposing undue financial and administrative burdens on industry.



**Published by:
COMMUNICATIONS
ALLIANCE LTD**

**Level 9
32 Walker Street
North Sydney
NSW 2060 Australia**

**PO Box 444
Milsons Point
NSW 1565**

**T 61 2 9959 9111
F 61 2 9954 6136
TTY 61 2 9923 1911
E info@commsalliance.com.au
www.commsalliance.com.au
ABN 56 078 026 507**

Care should be taken to ensure the material used is from the current version of the Standard or Industry Code and that it is updated whenever the Standard or Code is amended or revised. The number and date of the Standard or Code should therefore be clearly identified. If in doubt please contact Communications Alliance

ISBN: 1 74000 420 5