

**COMMUNICATIONS
ALLIANCE LTD**



INDUSTRY GUIDELINE

G635:2007

Testing Arrangements for Quality of Service
parameters for Voice over Internet Protocol
(VoIP) services

G635:2007 Testing Arrangements for Quality of Service parameters for Voice over Internet Protocol (VoIP) Industry Guideline

First published as G635:2007

Communications Alliance Ltd was formed in 2006 to provide a unified voice for the Australian communications industry and to lead it into the next generation of converging networks, technologies and services. ACIF is a division of Communications Alliance.

Disclaimers

1. Notwithstanding anything contained in this Industry Guideline:
 - (a) Communications Alliance disclaims responsibility (including where Communications Alliance or any of its officers, employees, agents or contractors has been negligent) for any direct or indirect loss, damage, claim, or liability any person may incur as a result of any:
 - (i) reliance on or compliance with this Industry Guideline;
 - (ii) inaccuracy or inappropriateness of this Industry Guideline; or
 - (iii) inconsistency of this Industry Guideline with any law; and
 - (b) Communications Alliance disclaims responsibility (including where Communications Alliance or any of its officers, employees, agents or contractors has been negligent) for ensuring compliance by any person with this Industry Guideline.
2. The above disclaimers will not apply to the extent they are inconsistent with any relevant legislation.

Copyright

© Communications Alliance Ltd 2007

This document is copyright and must not be used except as permitted below or under the Copyright Act 1968. You may reproduce and publish this document in whole or in part for your or your organisation's own personal or internal compliance, educational or non-commercial purposes. You must not alter or amend this document in any way. You must not reproduce or publish this document for commercial gain without the prior written consent of Communications Alliance. Organisations wishing to reproduce or publish this document for commercial gain (i.e. for distribution to subscribers to an information service) may apply to subscribe to the Communications Alliance Publications Subscription Service by contacting the Communications Alliance Commercial Manager at info@commsalliance.com.au. If you publish any part of this document for any purpose, you must also publish this copyright notice as part of that publication.

EXPLANATORY STATEMENT

This is the Explanatory Statement for the G635:2007 *Testing Arrangements for Quality of Service parameters for Voice over Internet Protocol (VoIP)* Industry Guideline.

This Explanatory Statement outlines the purpose of this Industry Guideline and the factors that have been taken into account in its development.

Background

The Internet Protocol (IP) is used for a range of services, some of which are sensitive to delays in packet delivery and to packet loss e.g. voice, video. The performance of these services benefit from having a defined Quality of Service (QoS).

Objectives of the Guideline

This Guideline provides a basis for a consistent approach to testing conversational voice quality for Voice over Internet Protocol (VoIP) services.

How the Objectives will be Achieved

The objectives will be achieved by the adoption by service providers of the testing approaches suggested in this Guideline.

Anticipated Benefits to Consumers

Consumers are likely to benefit from a consistent approach by service providers to the delivery of QoS for VoIP Services.

Benefits include the ability to make an informed choice of VoIP Services as well as improved confidence that the VoIP Services will operate as expected and will operate between different networks.

Anticipated Benefits to Industry

A consistent approach to the testing of QoS for VoIP Service by service providers will reduce the complexity and cost of testing, especially if the information is shared with other providers e.g. in resolving fault conditions.

Anticipated Cost to Industry

Anticipated costs include those associated with the use of an approach consistent with the information in this Guideline.

End of Explanatory Statement

Gary Marshall
Chairman

WC01 : Voice over IP Quality of Service Working Committee

TABLE OF CONTENTS

1	GENERAL	4
1.1	Introduction	4
1.2	Future Work	4
1.3	Scope	4
1.4	Objectives	4
1.5	Guideline review	4
2	ACRONYMS, DEFINITIONS AND INTERPRETATIONS	5
2.1	Acronyms	5
2.2	Definitions	6
3	INTRODUCTION	8
3.1	General	8
3.2	Suggested steps	8
4	TYPES OF TESTS	10
4.1	Introduction	10
4.2	Upfront quality assessment test (before ready for service)	13
4.3	Operational Quality Assessment (during service)	14
4.4	Fault condition test	14
5	TRANSPORT TEST SCENARIOS	16
5.1	Introduction	16
5.2	"Pure IP"	16
5.3	"TDM to IP" / "IP to TDM" with gateway	17
5.4	"IP to TDM to IP" with gateways	19
5.5	VoIP-TDM-Mobile	20
5.6	VSP-VSP	21
6	EQUIPMENT TEST SCENARIOS	23
6.1	Introduction	23
6.2	Analog phone to ATA	23
6.3	IP Handset	23
6.4	DECT phone to ATA	23
6.5	Wireless / WiFi enabled LAN segment	24
6.6	Private network e.g. IP PBX (performance ends at PBX)	25
7	WHAT PARAMETERS TO TEST IN VOIP SERVICE QUALITY	26
7.1	Introduction	26
7.2	Codec choice	26
7.3	Echo	26
7.4	Delay	27
7.5	Packet Loss	28
7.6	Loss Plan	28
8	OTHER FACTORS TO CONSIDER IN TESTING	30

8.1	Multiple Conversations	30
8.2	Miscellaneous (non-voice)	30
<hr/>		
9	SAMPLING FREQUENCY	31
<hr/>		
9.1	Overall sampling	31
9.2	Sampling within individual calls	32
<hr/>		
10	REFERENCES	33
<hr/>		
	APPENDIX	35
<hr/>		
A	SAMPLE PROCESSES	35
<hr/>		
	APPENDIX	36
<hr/>		
B	CONFIGURATION FOR LIVE QUALITY ASSESSMENT (OPERATIONAL TESTING)	36
<hr/>		
	APPENDIX	39
<hr/>		
C	CONFIGURATION FOR UPFRONT QUALITY ASSESSMENT (DESIGN TESTING)	39
<hr/>		
	APPENDIX	50
<hr/>		
D	EXAMPLES OF BASE CASE CALCULATIONS	50
<hr/>		
	PARTICIPANTS	59
<hr/>		
LIST OF FIGURES		
<hr/>		
FIGURE 1	'Pure IP' base case	17
FIGURE 2	"TDM to IP" / "IP to TDM" with gateway base case: TDM Access and Core, IP in access network	19
FIGURE 3	IP access, TDM Core, IP Access	20
FIGURE 4	IP access, TDM Core, Mobile Access	21
FIGURE 5	IP access, VSP Interconnect	22
FIGURE 6	Typical Working Network Performance Monitoring	38
FIGURE 7	Suggested Low-Cost Test Setup	38
FIGURE 8	Standard 2-Wire Telephone impedance	39
FIGURE 9	Standard Test Conditions	41

FIGURE 10	ATA/IAD Electrical Test	42
FIGURE 11	Handset test	42
FIGURE 12	Mouth-to-Ear delay for design testing	44
FIGURE 13	Validation of Echo Canceller Convergence – IAD/ATA for design testing	45
FIGURE 14	Validation of Echo Canceller Convergence – Gateways for design testing	46
FIGURE 15	Echo Return Loss	47
FIGURE 16	Send Loudness Ratings	48
FIGURE 17	Receive Loudness Ratings	48
FIGURE 18	Example 1 TELR for VoIP terminals with G.711 and WAN according to Y.1541 Class 0	51
FIGURE 19	Example 1 VoIP terminals with G.711 and WAN according to Y.1541 Class 0	52
FIGURE 20	Example 2 – TELR for VoIP islands with G.711 and PSTN	53
FIGURE 21	Example 2 – VoIP islands with G.711 and PSTN	54
FIGURE 22	Example 3 – TELR for VoIP to PSTN case of VoIP terminal with G.711 and PSTN with analogue terminal	55
FIGURE 23	Example 3 - – TELR for PSTN to VoIP case of VoIP terminal with G.711 and PSTN with analogue terminal	56
FIGURE 24	Example 3 - VoIP terminal with G.711 and PSTN with analogue terminal	57
FIGURE 25	Example 4 – TELR for VoIP terminals with G.729a and WAN according to Y.1541 Class 0	58
FIGURE 26	Example 4 – VoIP terminals with G.729a and WAN according to Y.1541 Class 0	58

1 GENERAL

1.1 Introduction

- 1.1.1 The development of the Guideline has been facilitated by Communications Alliance through a Working Committee comprised of representatives from the telecommunications industry and Government regulatory agencies.
- 1.1.2 The Guideline should be read in the context of other relevant Codes, Guidelines and documents, including the Industry Guidelines G632 and G634.
- 1.1.3 Statements in boxed text are a guide to interpretation only.

1.2 Future Work

- 1.2.1 Options for future work include the expansion of the choice of Customer Equipment, and the addition of more complex combinations of equipment and test scenarios.

1.3 Scope

- 1.3.1 This Guideline recommends testing methods for G634
- 1.3.2 The Guideline recommends testing arrangements for Quality of Service (QoS) parameters for Voice over Internet Protocol (VoIP) Services independent of the network delivery access or mechanism.

NOTE:

1. Refer to G632 for information on QoS performance in networks using the Internet Protocol (IP).

2. Refer to G634 for information on QoS performance for Voice over Internet Protocol (VoIP) services.

1.4 Objectives

The objective of this Guideline is to provide suggested testing arrangements for the quality of VoIP Services that service providers can use for the purposes of transmission planning, design verification, ongoing network monitoring, and to inform end-users.

1.5 Guideline review

Review of the Guideline will be conducted within five years of publication.

2 ACRONYMS, DEFINITIONS AND INTERPRETATIONS

2.1 Acronyms

For the purposes of the Code, the following acronyms apply:

ACIF	Australian Communications Industry Forum (Note)
ATA	Analogue Terminal Adapter
CE	Customer Equipment
Codec	COder / DECoder
DECT	Digital Enhanced Cordless Telecommunications
DUT	Device Under Test
ECAN	Echo Canceller
ERL	Echo Return Loss
IAD	Integrated Access Device
IETF	Internet Engineering Task Force
IP	Internet Protocol
IPDV	IP Packet Delay Variation
IPLR	IP Packet Loss Ratio
IPTD	IP Packet Transfer Delay
ITU-T	International Telecommunications Union – Telecommunications standardization sector
POI	Point Of Interconnection
QoS	Quality of Service
RFC	Request For Comment
RLR	Receive Loudness Rating
RTCP-XR	RTP Control Protocol Extended Reports
RTP	Real Time Protocol
SBC	Session Border Controller
SLR	Send Loudness Rating
TCLw	weighted Terminal Coupling Loss
TDM	Time Division Multiplex
TELR	Talker Echo Loudness Rating

TGW	Trunking Gateway
VAD	Voice Activity Detection
VoIP	Voice over Internet Protocol
VSP	VoIP Service Provider

NOTE: ACIF and SPAN merged in September 2006 to form the Communications Alliance.

2.2 Definitions

For the purposes of the Guideline, the following definitions apply:

Internet Protocol

means the protocol defined in the Internet Engineering Task Force (IETF) Request For Comment (RFC) 791.

IP Packet Delay Variation (IPDV)

has the meaning given by section 2.2 of G634.

IP Packet Loss Ratio (IPLR)

has the meaning given by section 2.2 of G634.

IP Packet Transfer Delay (IPTD)

has the meaning given by section 2.2 of G634.

Loudness Rating

has the meaning given by section 2.2 of G634.

Real Time Protocol (RTP)

means the protocol defined in IETF RFC 3550.

Receive Loudness Rating

means the loudness loss between an electric interface in the network and the listening subscriber's ear.

NOTE: This is based on ITU-T P.10/G.100.

RTP Control Protocol Extended Reports (RTCP-XR)

means the protocol defined in IETF RFC 3611.

Send Loudness Rating

means the loudness loss between the speaking subscriber's mouth and an electric interface in the network.

NOTE: This is based on ITU-T P.10/G.100.

Sidetone Path

has the meaning given by section 2.2 of G634.

Talker Echo Loudness Rating (TEL_R)

means the measure of the level of echo signal reflected back to the talker.

NOTE: TEL_R is usually expressed in the form of attenuation going from the talker all the way to the reflection point and back again to the talker (echo path).

Weighted Terminal Coupling Loss (TCL_w)

has the meaning given by section 4.2.21 of AS/ACIF S004.

VoIP Service

has the meaning given by section 2.2 of G634.

3 INTRODUCTION

3.1 General

- 3.1.1 Some guiding principles for testing VoIP Services include:
- (a) The prime responsibility for calculation of the R value lies with the party offering the VoIP Service(s) to end customers.
 - (b) There is a responsibility for each party to the supply of the VoIP Service(s) to deliver the advertised performance.
 - (c) Each party to the VoIP Service checks their own part e.g. a Time Division Multiplex (TDM) network operator, an IP network operator and a gateway operator should each check the performance of its respective part(s).
 - (d) In performing tests on VoIP Services (e.g. gathering RTCP-XR) information), some of the results may give an indicator of the performance of underlying network(s) because of the dependence of VoIP Service(s) on the correct operation of the transport path.
- 3.1.2 There are two major components to testing – the details of individual tests and the aspects of testing for statistical results.
- 3.1.3 Specifications to test individual calls may include:
- (e) the type of test;
 - (f) which parameters to measure;
 - (g) which parameters to verify; and
 - (h) which parameters to assume.
- 3.1.4 Specifications to test for statistical results may include:
- (a) the frequency of sampling calls overall (e.g. time of day, location, etc); and
 - (b) the frequency of sampling within individual calls (e.g. once per call, timing of tests if more than once per call, etc).

3.2 Suggested steps

The definition of testing arrangements should contain the following steps:

Step 1 – Type of test (refer to Section 4 for more information)

- 3.2.1 Choose the type of test for the conditions e.g. prior to deployment, operational, fault.

Step 2 – Scenario(s) (refer to Sections 5 and 6 for more information)

3.2.2 Identify the transport and equipment scenario(s) for the test type e.g. test an IP phone over a combination of TDM and IP networks, under operational conditions.

Step 3 – Parameters (refer to G634 for more information)

3.2.3 Identify the parameters to test for under the given scenarios and test type e.g. want to test IPTD/delay and IPLR/packet loss over a combination of TDM and IP networks, under operational conditions.

Step 4 – Configuration and Method (refer to Section 7 for more information)

3.2.4 Identify the recommended method for each given parameter e.g. how to test for delay under operational conditions.

Step 5 – Sampling frequency (refer to Section 9 for more information)

3.2.5 Identify the frequency of sampling both overall and within individual calls.

4 TYPES OF TESTS

4.1 Introduction

- 4.1.1 G634 is based on ITU-T Rec. G.107 and ITU-T Rec. G.108. ITU-T Rec. G.107 Section 3 states the E model "estimates the conversational quality from mouth to ear as perceived by the user at the receive side, both as listener and talker". Therefore for VoIP Services the appropriate test of quality is from mouth to ear.
- 4.1.2 Suggested approaches to testing include:
- (a) Upfront quality assessment – testing at the design phase.
 - (b) Operational testing – testing during normal operation.
 - (c) Fault testing – The investigation of operational results if they fall outside tolerance levels.
- 4.1.3 There can be a range of combinations of QoS at a voice service level and QoS at an IP transport level. Refer to Appendix D for examples of combinations of QoS at a voice service level. Refer to G632 for the description of IP Network QoS.
- 4.1.4 If the relevant VoIP Service(s):
- (a) operate over a network that is beyond the control of the VoIP Service provider (VSP), then the VSP could make an assumption about network performance.
 - (b) are bundled with network access then the VSP should use real values to assess performance.
- 4.1.5 In looking at end-to-end performance, a service design may start with good performance but once one starts interconnecting with other networks/services then end-to-end performance may be reduced. Therefore there are a number of factors to be aware of including:
- (a) understanding which components of a service are managed e.g. this may exclude the performance of a LAN.
 - (b) recognising that different VSPs can behave differently in a multi-call case.
 - (c) understanding a potential problem for end users at present arises from other traffic e.g. web browsing or other general Internet use such as email with a simultaneous voice call.
- 4.1.6 There are two components in developing details of tests:
- (a) test details for each call; and
 - (b) statistical testing details across calls or within a call.
- 4.1.7 The primary measure for the quality of a VoIP Service is an R value (refer to ITU-T Rec. G.108) determined using the E model (refer to

ITU-T Rec. G.107). Refer to G634 for more information on categories of R values for VoIP Services in Australia.

- 4.1.8 The major readily measured and identified factors that have an impact on R value for a VoIP Service are:
- (a) Codec choice.
 - (b) Echo. If Echo is not managed well then it can be audible even on a low delay call.
 - (c) Delay, including jitter. This should be assessed under realistic traffic situation(s).
 - (d) Packet loss. For most codecs, including G.711, packet loss concealment may be possible. (refer to G.711 Appendix I)
 - (e) Loudness rating. The Australian standard is 1dB from ITU-T levels (refer to ITU-T Rec. G.121 and AS/ACIF S004, Table 1) which means an impact of reducing QoS by 1 or 2 R points (not a significant impact). One can assume these values for operational tests, but loudness levels should be tested as part of an upfront quality assessment.
- 4.1.9 Other factors in the E model that have less impact on R value and that can usually be assumed (because of their lesser impact) are:
- (a) Noise levels. Room noise – the E model has a standard model for indoor use, and mobile use can have higher levels. One can assume the default value is that for indoor use i.e. effectively testing in a silent environment. Circuit noise and noise floor levels are assumed to be default values.
 - (b) Sidetone path – one can assume a default value.
 - (c) A or Advantage – for the simplest case one can assume a value of 0.

NOTES:

1. Setting A to a value of 0 allows comparison of the voice quality across different media, whereas assuming a higher value for A factors in the convenience of using the service (e.g. mobility in a geographical area or moving in a vehicle). Refer to Table 1 in ITU-T Rec. G.107 for a list of provisional A values.

2. One should measure and report the objective call quality without the A value.

- (d) D or design value – one can assume the default value for the telephone (from ITU-T Rec. G.107) of 3 on the send and receive sides.

- (e) Transcoding – For a simple case one can assume testing involves only one codec (i.e. no transcoding). If using more than one codec (i.e. transcoding) add the relevant impairment value (i.e. l_e) of each codec. Refer to Table I.1 in ITU-T Rec. G.113 Amendment 2 for l_e values.

NOTE: The use of additional coding methods (e.g. through use of a Digital Enhanced Cordless Telecommunications (DECT) phone connected via an ATA) may add complexity to the assessment of the impact of transcoding.

- 4.1.10 The assessment of the quality of a VoIP Service using the E model requires identification of factors that can be measured and factors that can be assumed.
- 4.1.11 For a base case the following assumptions about the type of equipment apply:
 - (a) For the use of a PC headset with a softphone, testing needs to be representative of a day-to-day user's environment, i.e. testing to be conducted in this setup then measurements should be conducted with competing device intensive applications (e.g. other CPU intensive applications) in operation;
 - (b) For the use of a standard/fixed/PSTN phone connected to an ATA, equipment must align with the relevant Customer Equipment standards: e.g. AS/ACIF S002, AS/ACIF S003, AS/ACIF S004.
 - (c) For the use of an integrated IP phone, assume it has built in echo cancellation.
 - (d) For the use of a DECT phone, assume it connects to the VoIP Service via an ATA.
- 4.1.12 Assumptions for test conditions should include that:
 - (a) The basic test environment approximates what has been / is to be advertised. Examples for the basic call case include:
 - (i) the maximum number of simultaneous calls; and
 - (ii) whether it is dedicated to voice only services with no underlying traffic, or is part of a multiservice connection that carries voice and other applications.
 - (b) The access link bandwidth is dimensioned to accommodate overhead.

NOTE: Signalling packets arrive at random times and are an overhead that may affect performance.

- (c) Testing is done by either:
- (i) measurement (e.g. test end to end for a single call scenario); or
 - (ii) assessment (e.g. test one call scenario and adjust the result for different scenarios).

4.1.13 Other areas that can add complexity include:

- (a) calls covering more than one "Quality" category, as defined in G634 e.g. with a given subscription package one might find 95% of calls meet the minimum R value quoted for a Category and then also report the probability of meeting the requirements of a higher Category.
- (b) The amount of bandwidth that should be made available.
- (c) The number of calls over a given access link. The performance of a VoIP Service when one call is in progress will differ from the performance when the maximum number of calls are in progress.

4.1.14 Given the above information, a basic test approach to obtain a good estimation of the R value is to:

- (a) Know what the echo canceller (ECAN) is doing;
- (b) Measure the delay;
- (c) Know the codec(s) in use; and
- (d) Measure the packet loss.

4.2 Upfront quality assessment test (before ready for service)

4.2.1 Relevant factors include the:

- (a) use of a mouth-to-ear test set up;
- (b) choice of codec;
- (c) minimum recommended data rate e.g. access line speed;

NOTE: On like-with-like testing that uses an asymmetric broadband access link, the limit is likely to be the upstream data rate at each end.

- (d) default settings for testing a jitter buffer;
- (e) use of dedicated equipment for voice (e.g. a PC not being used for web browsing and a voice call simultaneously); and

- (f) use of background 'best effort' traffic to reflect typical use.

NOTE: If a test does not include background traffic then the test is valid only in an equivalent operational scenario for a VoIP Service operating with the presence of no other applications e.g. no web browsing.

- (g) Recognition that QoS enabled IP Network traffic can get competition from traffic at lower, the same and higher traffic classes.

4.3 Operational Quality Assessment (during service)

- 4.3.1 A mouth-to-ear test setup is difficult to achieve for operational testing on calls in progress so one should rely on other measurable elements described below.
- 4.3.2 Ongoing/operational performance testing is recommended to enhance confidence in a provider's service e.g. for its ability to meet requirements of a service level agreement.

NOTE: Ongoing/operational performance testing does not reflect the performance of an individual service.

- 4.3.3 A suggested method that can be effective is snooping RTCP-XR packets in the core. Refer to Figure 7 for an example.
- 4.3.4 If RTCP-XR statistics are available, then for ongoing/operational tests the QoS can be compared using default noise levels from the E-model (refer to Table 2 in ITU-T Rec. G.107).
- 4.3.5 If RTCP-XR statistics are not available, then for ongoing/operational tests:
- (a) the utilisation of the access link should be at the standard operational level(s).
 - (b) the level of background noise for a test should be similar to operational conditions e.g. typical office, factory, home.

4.4 Fault condition test

- 4.4.1 A mouth-to-ear test setup cannot be achieved for fault condition testing so one should rely on other measurable elements described below.
- 4.4.2 The location of the trust boundary can affect test results. For example, the inclusion/exclusion of customer equipment, such as a modem, in/from a trusted network can affect test results.
- 4.4.3 A starting assumption for fault testing is that the VoIP Service has been working and the R value has degraded from the usual performance.

- 4.4.4 Where fault testing undertaken by the provider with prime responsibility for the VoIP Service:
- (a) confirms there is a problem with the quality of the VoIP Service; and
 - (b) identifies the source of problem

then the matter should be referred to the relevant provider for resolution e.g. service provider, network operator, gateway provider.

NOTE: Details on fault resolution processes are outside the scope of this guideline.

- 4.4.5 If the VoIP Service is capable of supporting multiple applications then a diagnostic process for fault conditions might include getting the end user to use multiple applications (e.g. transmit email, browse webpages) at the same time as making a voice call.

NOTE: Post dial delay (PDD) is outside the scope of this Guideline because it precedes voice transmission and therefore does not directly affect the quality of the VoIP Service. Post dial delay is of interest for overall end user experience.

- 4.4.6 Appendix A1 contains proposed fault handling processes.

5 TRANSPORT TEST SCENARIOS

5.1 Introduction

- 5.1.1 This section introduces a number of base cases for different scenarios, with possible variations on each base case.
- 5.1.2 Testing of all scenarios is not required. The choice of scenarios for testing should reflect operational cases.
- 5.1.3 The intent is for the simplest case (i.e. base case) for each scenario to reflect "like to like" testing e.g. the use of similar endpoint configurations with the same codecs. For example, if one were to call from a G.711 based service to a G.729 based service then one can only expect a category of performance consistent with use of a G.729 codec at each end of the call.
- 5.1.4 By definition, the "TDM to IP / IP to TDM" scenario (see section 5.3) may not be symmetrical. The implication of this is that one should measure in both directions.
- 5.1.5 If testing returns noticeably different results in the different directions then one should treat each direction as a different scenario.

NOTES:

1. There are existing Codes and Guidelines for performance of voice services on TDM network(s), such as ACIF C519. This Guideline focuses on VoIP cases.

2. The principal constraints on the performance of TDM networks are optical delays and the (typically analogue) access network.

5.2 "Pure IP"

- 5.2.1 The base case for the "Pure IP" scenario (refer to Figure 1) is the connection of two endpoints:
 - (a) via one VSP; and
 - (b) transported over one IP network; where
 - (c) the VSP and IP network have common operation/control; and
 - (d) the digital encoding/decoding of the analogue signal occurs in the customer equipment.

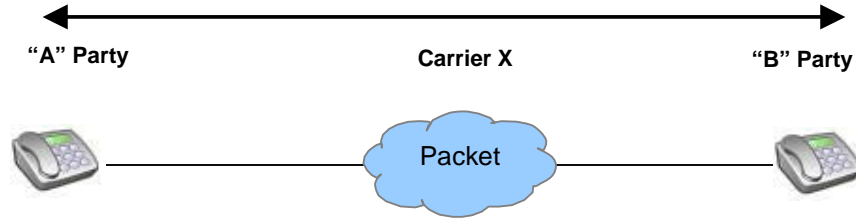

FIGURE 1
'Pure IP' base case

5.2.2 Variations on the base case include:

- (a) the use of more than one IP network for transport;
- (b) separate operation of the IP transport and the VSP (the VSP would assume/contract for a Class 0 IP network for transport.);
- (c) the participation of more than one VSP (i.e. typically two VSPs);
- (d) the use of different access networks; and
- (e) the digital encoding/decoding of the analogue signal at the exchange/node.

NOTE: Where an analogue access tail converts to an IP based transport at an exchange/node then one must allow for the additional loss arising from the line length to the exchange. This potentially affects send loudness, receive loudness and circuit noise.

5.3 "TDM to IP" / "IP to TDM" with gateway

5.3.1 The base case for this scenario (refer to Figure 2) is a VoIP Service that uses:

- (a) an IP based network for transport connecting with a TDM network, or vice versa.
- (b) a gateway to convert between IP and TDM based networks e.g. based on ITU-T Rec. H.248 / RFC 3015.
- (c) one codec i.e. involves no transcoding.

NOTES:

1. This base case is the most common scenario at the time of publication.

2. The 'ideal' G.711 VoIP-PSTN call setup could achieve Category C quality as defined in G634 for 95% of call cases. A common

VoIP scenario of using, say, G.729 codecs would lower the R score by approximately 10 (i.e. to Category B).

3. Transit exchange impact is small in terms of its impact on the R value for a call (i.e. Table A.1 of ITU-T Rec. G.114 has a planning value of 0.45ms delay for a digital transit exchange).

4. The use of a gateway function is likely to need a degree of performance checking. For example, a gateway provides, and one expects to see change(s) in:

a. The overall loudness rating for an exchange based service rather than an on premises service.

b. Echo. A gateway needs to have long echo tails, which doesn't apply to 'in house' echo cancellation.

5. IP parameters terminate at a gateway (e.g. packet loss) but the quality experience for an end user includes the TDM network.

6. Impact on loudness remains the same, but loudness on a TDM call is degraded by a maximum of 7dB, probably around 3dB average (e.g. ACIF C519 assumes 3dB loss in an access network).

7. Packet loss is only relevant between the Customer Equipment connecting to the IP network and the gateway.

8. Delay is an end-to-end test. A TDM network has a delay, but IP and TDM information typically travel over the same optical fibres. Therefore although the TDM based network delay might be slightly less than in the IP based case one could assume the same optical component of delay for a given segment transported over either TDM or IP based network(s).

9. An ECAN is typically in an IAD/ATA and in a gateway but not in an analogue telephone handset. There might be an additional ECAN located in the TDM network.

10. For TDM-TDM networks the location of ECANs is optimized. For IP-TDM it may not be optimized, and one would see a small degradation (estimated as approximately half a Quantizing Distortion Unit, a slight impact on the R value).

5.3.2 Variations on the base case include the:

- (a) use of a long analogue tail.
- (b) independence of the VSP from a third party access service.
- (c) use of compression in the VoIP network (e.g. G.729).
- (d) use of more than one codec.

*NOTE: For VoIP Services using a long analogue tail:
(a) Noise on the local loop has an impact on impairment.
(b) One can assume a 3dB loss.
(c) Both sides of a gateway are digital.
(d) Jitter buffers and coding delays are now in the trunking gateway (TGW). One can approximate it as a substitution of the gateway for Customer Equipment (CE).*

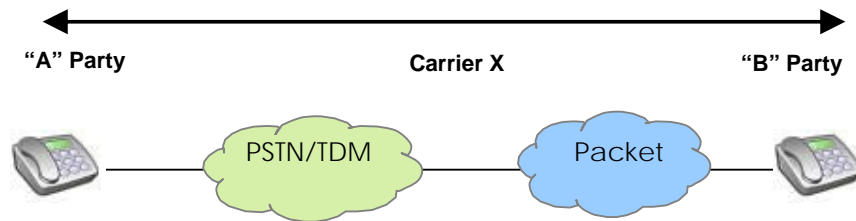

FIGURE 2

**"TDM to IP" / "IP to TDM" with gateway base case:
TDM Access and Core, IP in access network**

5.4 "IP to TDM to IP" with gateways

5.4.1 The base case for this scenario (refer to Figure 3) is a VoIP Service that:

- (a) uses a TDM network(s) for transport (e.g. for transit) between two IP networks.
- (b) connects services from two different VSPs.

NOTES:

1. This scenario assumes if there is only one VSP (i.e. an on-net call) then the call would be transported as IP only and there is no need for a TDM transit path.

2. The IP to TDM to IP conversion may add approximately 10 to 40ms to a call. This could extend a 170ms delay to over 200ms, with consequential impact on the R score.

5.4.2 Variations on the base case include the:

- (a) use of a TDM network that operates with an IP core.
- (b) independence of one VSP from the access service supplied by a third party.
- (c) independence of both VSPs from the access services supplied by a third party.

- (d) independence of each VSP from the respective access service supplied by third parties.
- (e) use of different codecs at the end-points, resulting in transcoding.

NOTES:

1. While less than ideal in terms of transcoding and delay, the connection of two IP based voice services via a TDM network may be commercially attractive. For example, where the TDM network provides a call termination service with associated number lookup and routing function(s).

2. It is feasible to implement this scenario with end-to-end delay of 150ms across a TDM network and with G.711 codecs but this is unlikely with compressing codecs such as G.729.

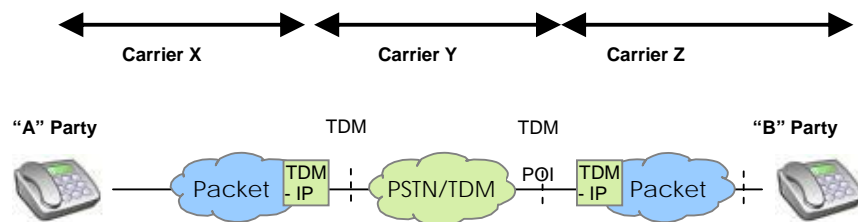

FIGURE 3
IP access, TDM Core, IP Access

5.5 VoIP-TDM-Mobile

5.5.1 The base case for this scenario (refer to Figure 4) is:

- (a) a VoIP Service that uses a TDM network(s) for transport (e.g. for transit) between an IP network and a mobile network.

NOTES:

1. This potentially means different codecs at each end with transcoding to/from G.711 in the middle. This multiple transcoding would have an additional impact on the R value compared to a single codec or no transcoding.

2. A GSM to PSTN call is estimated to have a maximum R value of 88. Under radio propagation loss conditions this maximum value will degrade further. For example, the impairment values in Table 1.2 in Appendix 1 of G.113 indicate the impact of using codecs that are frequently used for mobile telephony.

5.5.2 A variation on the base case includes the use of a TDM network that operates with an IP core.

NOTE: A 3G IP phone used for data transport for a third party VoIP Service does not apply in this scenario – refer to the Pure IP, IP-TDM and VSP-VSP scenarios where the VSP is independent of the underlying network.

5.5.3 Other factors to consider include:

- (a) delays in all three networks would be concatenated.
- (b) indicative delays on mobile networks.
- (c) advantage factor.

NOTE: One should measure and report the objective call quality without the A value.

- (d) ambient noise – it is generally higher for a mobile user compared to a non-mobile user.
- (e) the higher probability of errors on the radio access link.

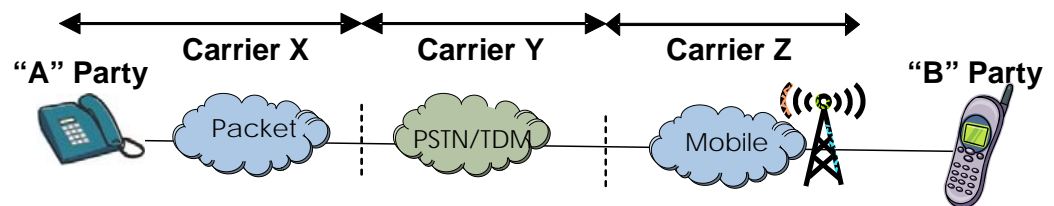

FIGURE 4
IP access, TDM Core, Mobile Access

5.6 VSP-VSP

5.6.1 The base case for this scenario (refer to Figure 5) is a VoIP Service that:

- (a) uses G.711 codecs at both endpoints.
- (b) uses a single Point Of Interconnection (POI).
- (c) operates on a Class 0 network, as defined in G632.

NOTES:

1. This could be the "Pure IP" case of section 5.1 with the variation to separate the service provision from the underlying network(s).

2. Endpoints should negotiate codec use, and in the 'worst' fallback case, both use G.711 in order to avoid transcoding.
3. It is possible that the case of a single POI in Australia could result in a call travelling from Sydney to Perth to Sydney i.e. a local call in Sydney using a Perth based VSP. However this adds about 40ms of optical transport.

5.6.2 Variations on the base case include the use of:

- (a) different codecs.
- (b) multiple VSPs and POIs.

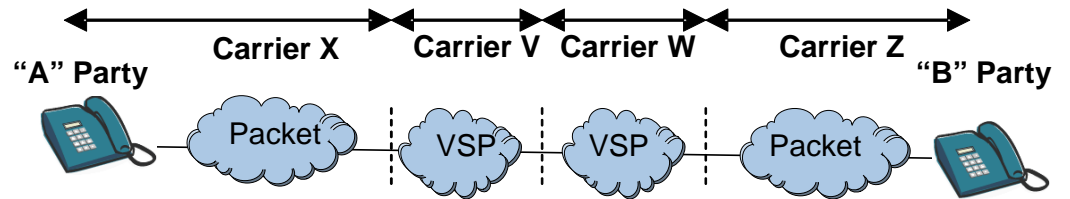

FIGURE 5
IP access, VSP Interconnect

6 EQUIPMENT TEST SCENARIOS

6.1 Introduction

- 6.1.1 The test scenarios below refer to an "electrical interface test" and an "acoustic interface test". Refer to Appendix C, sections C.4 and C.5 respectively for more information on these tests.

NOTES: AS/ACIF S004 provides standard test conditions for CE with an acoustic interface.

6.2 Analog phone to ATA

- 6.2.1 The test should be conducted with measurements at the electrical interface.
- 6.2.2 Refer to Appendix C, Section C4 for a test configuration with an electrical interface test set up for an IAD/ATA.

NOTES:

1. In practice the codecs and networks in use vary so measuring from a 2-wire point to a 2-wire point can be tested more readily than at a 4-wire point.

2. For monitoring on a larger scale, such as under operational conditions, a suggested approach is to capture packets in the network. This typically involves taking a sample around a few points in a network.

6.3 IP Handset

- 6.3.1 The test should be conducted with measurements at the acoustic interface.

NOTE: AS/ACIF S004 provides standard test conditions for CE with an acoustic interface.

- 6.3.2 Refer to Appendix C, Section C5 for a test configuration with an acoustic interface test set up for a handset.

6.4 DECT phone to ATA

- 6.4.1 The test should be conducted with measurements at the acoustic interface.

NOTES:

1. This is because one does not have access to an electrical interface.

2. It is important to acoustically isolate the two acoustic interfaces for each endpoint.

- 6.4.2 The DECT phone is assumed not to have competing traffic from other applications.

6.5 Wireless / WiFi enabled LAN segment

- 6.5.1 The test should be conducted using an acoustic interface or electrical interface.

NOTES:

1. For connection through an IAD via WiFi one should use an electrical interface test – refer to Appendix C, Section C.4.

2. For connection of a headset via WiFi one should use an acoustic interface test– refer to Appendix C, Section C.5.

3. If the underlying network is QoS enabled, delays over WiFi are likely to be lower, with better performance, than if the network is not QoS enabled. QoS enablement for WiFi is planned, and is specified in WiMax.

- 6.5.2 The test set up should:
- (a) locate the handset or headset in close proximity to the base station. For example, less than 2m separation;
 - (b) have no obstructions to the wireless path;
 - (c) have no distortions to the wireless path e.g. nearby metal objects;
 - (d) orient the antenna and equipment for optimal performance; and
 - (e) operate in a manner that reflects typical operational performance, including (where appropriate):
 - (i) the presence of competing 'best efforts' traffic;
 - (ii) simultaneous calls; and
 - (iii) the presence of other services e.g. email, web browsing.

NOTES:

1. Packet loss can vary with distance from the base station and signal strength.

2. If the VSP provides the LAN set up as part of a package then that would be part of typical operational performance and should be part of the test set up.

3. Different standards 802.11a, b, g and n lead to different performance depending on configurations and it is difficult to specify performance generally.

4. WiFi reduces the transmission rate on longer paths from the base station. Speed slows to achieve a similar error rate.

5. WiFi products vary in terms of their compliance.

6.6 Private network e.g. IP PBX (performance ends at PBX)

6.6.1 The test should be conducted using an acoustic interface or electrical interface.

NOTE: If IP handsets are connected to an IP PBX or gateway then use an acoustic interface test- refer to Appendix C, Section C.5. Otherwise perform an electrical interface test- refer to Appendix C, Section C.4.

7 WHAT PARAMETERS TO TEST IN VOIP SERVICE QUALITY

7.1 Introduction

7.1.1 The parameters outlined below are the primary factors considered as impacting the voice quality of a VoIP Service. A base set of assumptions are introduced for each parameter.

7.1.2 Assumptions for a test setup include:

- (a) silence detection, background noise / Voice Activity Detection (VAD) is on/off as per the standard service offering.

NOTE: In ITU-T Rec. G.107 the impairment value for the G.729 codec is 10 and for the G.729a codec (which includes VAD) is 11. Therefore properly implemented VAD has minimal degradation on the R score. Therefore it can be used to improve bandwidth utilisation without having a substantial impact on the voice quality.

- (b) session border controllers are set up as per the standard service offering.

NOTE: Some session border controllers have trouble with VAD because it appears that the call has ceased and the session border controller drops the call.

- (c) jitter buffers are set as per standard service offering.

NOTE: Jitter buffers can have varied functionality between vendors and between software releases.

7.2 Codec choice

7.2.1 Identify the codec in use. Possible methods include the use of RTCP-XR or CE information.

7.2.2 Assume that codec performance is to specification and not tested.

NOTE: Identify the codec for the purpose of an input to calculation of the R value.

7.3 Echo

7.3.1 The simplest configuration for testing echo is a regular analogue phone (refer to AS/ACIF S002 for requirements) within 2m of an IAD.

7.3.2 Suggested steps for determining echo are:

- (a) confirm the use of echo cancellation,

- (b) assume one is using ITU-T Rec. G.168 compliant ECAN(s) with default settings/values;
- (c) assume there is a good impedance match (as a mismatch at a phone could cause problems),
- (d) confirm that the echo cancellation is effective – check that the ECAN is effective. For example, let the ECAN converge, then send a tone burst and check if there is a tone burst returned in the reverse direction.

NOTE:

1. ECANs take about 1 second of single-directional speech to converge.

2. A Talker Echo Loudness Rating (TELRL) target of 65dB provides the optimum value for reducing echo. This is also the default TELRL value in the E-model – refer to Table 2 in ITU-T Rec. G.107.

3. As a variation on the base case and an example that adds complexity is using an exchange based VoIP Service with analogue service to the customer premises (rather than premises based conversion to IP). The loss along an analogue line between an exchange and a customer will impact on the loudness and therefore will make the echo more audible.

7.4 Delay

- 7.4.1 The total delay (under realistic traffic situations) includes the jitter buffer delay.
- 7.4.2 Delay is relatively easy to measure in one location as one inserts a signal and measures elapsed time for it to return.
- 7.4.3 Because delay can vary in a call, one should measure it a number of times within a call.
- 7.4.4 The simplest case is measuring the delay of one call. Refer to Section 9 for more information on sampling larger numbers of calls.
- 7.4.5 A recommended method to measure delay is:
 - (a) the process should be long enough for ECANs to stabilise and for packet buffers to fill up.
 - (b) it is preferable to use a measured value as taken from RTCP-XR statistics or via a method specified in Appendix C.2. The advantage of measurements are they reflect real performance; where measurements are not available, design value(s) may be used for simplicity.

NOTE: One should refer to ITU-T Rec. G.114 for a methodology on estimating delay.

- 7.4.6 For operational testing one could measure at the IP layer network end points and add/allow for the defined coding delays in equipment.

7.5 Packet Loss

- 7.5.1 Notes on Packet loss:

- (a) the E model has parameters defining the impact of packet loss on the le parameter of the codec

NOTES:

1. Refer to Table I.2 in ITU-T Rec. G.113 for impairment under random packet loss with various codecs.

2. Refer to Table I.3 in ITU-T Rec. G.113 for impairment under packet loss in G.711.

- (b) the simplest case is to take real measures and put in packet loss under realistic traffic situations. If sampling Real Time Protocol (RTP) statistics then packet loss can be assumed to be random. If using RTCP-XR statistics provided from an accurate source then packet loss will be known to be random or bursty and appropriately used in the R model.
- (c) during planning one should put in expected values of packet loss in the network(s).

- 7.5.2 Packet loss can be measured for both upfront and operational tests. It might also be required for fault testing.

- 7.5.3 Testing should statistically reflect operational conditions of all calls made.

NOTES:

1. If using packet loss concealment with G.711 there will be compensation for the packet loss.

2. Packet loss concealment techniques can be built into codecs such as iLBC or appended to a decoder such as for G.711.

7.6 Loss Plan

- 7.6.1 In cases where the device under test has an acoustic output then measurements to determine loudness ratings for headsets should use an acoustic interface. Refer to Section C.5 for more information on testing using an acoustic interface.

- 7.6.2 In cases where the device under test does not have an acoustic output (e.g. IADs) then send and receive levels should use the loudness rating of standard analogue telephone(s) for input to the E model (refer to Table 1 of AS/ACIF S004).
- 7.6.3 If one is measuring in the core of the IP network then loss cannot be calculated and should be assumed.
- 7.6.4 Refer to section 4.6.11 in G634 for discussion of the optimum Overall Loudness Rating (OLR).
- 7.6.5 A variation that can add complexity is where the ATA may perform loudness level control. This is done to try to optimise the loudness rating and can be assumed not to degrade the R value.

8 OTHER FACTORS TO CONSIDER IN TESTING

8.1 Multiple Conversations

- 8.1.1 If equipment supports multiple conversations then one should test it under operational conditions.
- 8.1.2 When VoIP equipment supports multiple simultaneous conversations, different conversations are active at different times under operational conditions.
- 8.1.3 During planning, performance should be measured using the maximum loading of simultaneous calls.

8.2 Miscellaneous (non-voice)

- 8.2.1 Other non-voice factors can be tested but are out of scope of this document. Examples include:
 - (a) DTMF for voice-response systems or home banking;
 - (b) frequency response test e.g. tones ranging from 50Hz to 20kHz;
 - (c) amplitude response test e.g. amplitudes gradually changing from 0 to -90dB;
 - (d) VAD detection; and
 - (e) TTY for the hearing impaired e.g. a test track with TTY signals (at least 100 characters).

9 SAMPLING FREQUENCY

9.1 Overall sampling

- 9.1.1 Overall sampling patterns for operational testing should be generally representative of calling patterns. Factors to consider in planning the test(s) include distribution of calls based on:
- (a) geography;
 - (b) time of day;
 - (c) day of week; and
 - (d) testing for relevant scenarios.

NOTES:

1. The ITU-T P series Recommendations (on Telephone transmission quality, telephone installations, local line networks, refer to <http://www.itu.int/rec/T-REC-P/e>) and Y series Recommendations (on Global information infrastructure, Internet protocol aspects and next-generation networks, refer to <http://www.itu.int/rec/T-REC-Y/e>) include information on the frequency of operational testing for voice services.

2. ACIF C519 defines a sampling methodology for voice services over the TDM network and can be used here.

- 9.1.2 Operational testing should distribute the measurements across the observation period. It is important to observe the impact of factors across the month(s) of observation in order to include the impact of factors such as network growth.
- 9.1.3 The sampling accuracy in the Test Plan should be greater than or equal to the statistical measure of 95% degree of confidence for the target value e.g. 95% of calls.

NOTES:

1. Different parameters have different importance for quality and therefore might be tested at different intervals.

2. Some factors can vary from hour to hour and some from month to month.

3. For ongoing testing the three main parameters are likely to be, delay, packet loss and underlying jitter.

- 9.1.4 Providers should re-assess on a regular basis whether the calling patterns of test calls are representative and make required

changes to ensure its test plan continues to be representative of its calling patterns.

NOTE: When determining the test call sample, each of the parameters for establishing a representative sample can be determined, and test calls assigned, without needing to cross reference to other parameters.

- 9.1.5 One may exclude the effects of faulty test equipment from test results.

NOTE: This can help avoid reporting as faulty a VoIP Service operating within its performance targets when a faulty component of a test set up distorts test results.

9.2 Sampling within individual calls

- 9.2.1 Within an individual call the sample method will depend in part on the type of test. For example, an initial diagnostic test for a fault condition is the binary test of being able to make a call or not make a call.
- 9.2.2 It is preferable to sample a whole call, but a sample from within a call can be made when sampling in the middle of the network.
- 9.2.3 For testing prior to deployment and for ongoing operational tests:
- (a) each voice call should be randomly sampled.
 - (b) if sampling from within a call (as opposed to a whole call) it is preferable to obtain sample points across multiple calls rather than from within the one call.

NOTE: RTCP is inherently random.

10 REFERENCES

Publication	Title
Australian/ACIF Standards	
AS/ACIF S002:2005	Analogue interworking and non-interference requirements for Customer Equipment for connection to the PSTN
AS/ACIF S003:2006	Customer Access Equipment for connection to a Telecommunications Network
AS/ACIF S004:2006	Voice frequency performance requirements for Customer Equipment
ETSI Specifications	
ES 201 168 V1.2.1 (2000-10)	Speech Processing, Transmission and Quality Aspects (STQ);Transmission characteristics of digital Private Branch eXchanges (PBXs) for interconnection to private networks, to the public switched network or to IP gateways
IETF RFCs	
RFC 791	Internet Protocol
RFC 3015	Megaco Protocol Version 1.0
RFC 3550	RTP: A Transport Protocol for Real-Time Applications
RFC 3611	RTP Control Protocol Extended Reports (RTCP XR)
Industry Codes	
ACIF C519:2004	End-To-End Network Performance
Industry Guidelines	
G632:2007	Quality of Service parameters for networks using the Internet Protocol Guideline
G634:2007	Quality of Service parameters for Voice over Internet Protocol (VoIP) services
ITU-T Recommendations	
G.107 (03/05)	The E-model, a computational model for use in transmission planning
G.108 (09/99)	Application of the E-model: A planning guide
G.108 Amdt 2 (03/04)	Application of the E-model: A planning guide Amendment 2; New Appendix II – Planning examples regarding delay in packet-based networks

G.113 (02/01)	Transmission impairments due to speech processing
G.113 (2001) Amendment 2 (01/07)	Revised Appendix I - Provisional planning values for the equipment impairment factor I_e and packet loss robustness factor B_{pl}
G.121 (03/93)	Loudness ratings (LRs) of national systems
G.711 (11/88)	Pulse code modulation (PCM) of voice frequencies
G.711 Appendix I (09/99)	A high quality low-complexity algorithm for packet loss concealment with G.711
G.711 Appendix II (02/00)	A comfort noise payload definition for ITU-T G.711 use in packet-based multimedia communication systems
G.729 (01/07)	Coding of speech at 8 kbit/s using conjugate-structure algebraic-code-excited linear prediction (CS-ACELP)
H.248 (06/00)	Gateway control protocol
P.10/G.100 (07/06)	Vocabulary for performance and quality of service
P.50 (09/99)	Artificial voices
P.564 (07/06)	Conformance testing for narrowband voice over IP transmission quality assessment models
P.1010 (07/04)	Fundamental voice transmission objectives for VoIP terminals and gateways
Y.1540 (12/02)	Internet protocol data communication service - IP packet transfer and availability performance parameters

URLs for some of the above references are:

<http://pda.etsi.org/pda/queryform.asp>

<http://www.ietf.org/rfc.html>

<http://www.itu.int/ITU-T/publications/recs.html>

<http://commsalliance.com.au/> OR <http://commsalliance.com.au/documents>

APPENDIX

A SAMPLE PROCESSES

A1 Fault Condition Testing Process for Voice Quality

- A.1.1 An initial test process for fault diagnosis may be similar to the following:
- (a) customer makes complaint.
 - (b) provider asks customer to ring a nominated transponder.
 - (c) provider captures the speech path for playback.
 - (d) call made via an ATA to an automatic answering machine.
 - (e) recorded Voice announcement (RVA) plays back
 - (f) monitoring equipment captures information, including echo.
 - (g) provider plays back speech to see if there is echo.
 - (h) packet information indicates what loss and jitter values arise from the test.
 - (i) depending on the number of test points, provider gets a sampled output for further diagnostic purposes.

A2 Fault Condition Testing Process using IP Network Parameters

- A.2.1 An alternate test process when a fault condition exists (using different test equipment to that in A1) is:
- (a) customer places a call to a test server,
 - (b) the server downloads a test pattern (e.g. via/using javascript).
 - (c) the test pattern runs
 - (d) the test returns values for parameters such as packet loss, jitter, predicted quality measure, etc.

APPENDIX

B Configuration for Live Quality Assessment (Operational Testing)

B1 Introduction

- B.1.1 This Appendix provides information on testing under operational conditions in relation to:
- (a) assumptions and estimated test conditions;
 - (b) possible testing methods; and
 - (c) possible test configurations.
- B.1.2 The information included here does not limit the options for operational testing. Organisations may perform more or less testing based on operational needs (e.g. service level agreements).

B2 Assumptions

- B.2.1 It is preferred to measure actual customer behaviour, wherever possible. However, unless all VoIP equipment supports RTCP-XR statistics, some E-Model parameters must be estimated, for example:
- (a) The mix of CE may be obtained from sales records.
 - (b) The mix of codecs and packetisation delays may be obtained from SDP messages.
 - (c) The call scenario (IP-IP, IP-PSTN, IP-Mobile, etc) may be inferred from the called number.
 - (d) The call distance/delay may be inferred from RTP statistics or call records.
 - (e) Send Loudness Rating (SLR) and Receive Loudness Rating (RLR) may assume "nominal" Australian telephones
 - (f) Jitter buffer behaviour may be estimated from lab testing of end-to-end delays.
 - (g) Ambient noise may be left at the E-Model default.
- B.2.2 For calls crossing hybrid networks (e.g. PSTN or mobile), other measures of call quality must be collected, and related back to R-Values, or 'typical' impairments assumed for these other networks.

B3 Operational Testing Process for Voice Quality

- B.3.1 An operational test process may be similar to the following:
- (a) On a planned basis, make test calls between selected destinations. Record the RTCP-XR statistics.
 - (b) For each call scenario, estimate the R-Value. If certain parameters are unknown, they may be estimated.
 - (c) Allocate proportions to each call scenario.
 - (d) Identify the 95% call quality for "on-net" and "off-net" calls.

B4 Operational Testing Process using IP Network Parameters

- B.4.1 An alternate operational test process (using different test equipment to that in Section B.1) is:
- (a) Collect RTCP-XR statistics in the network core, representing the mix of actual customer calls.
 - (b) Extract the R-Value from these calls.
 - (c) Identify the 95% call quality for "on-net" and "off-net" calls.

NOTE: RTCP-XR statistics provide information on ECAN convergence and delay; if RTCP-XR statistics are not available, then design values as outlined previously should be used.

B5 Operational Test Configuration 1 – Typical Working Network Performance Monitoring

- B.5.1 In Figure 6, the performance statistics of real calls are sampled within the network core and provide visibility of the R value.

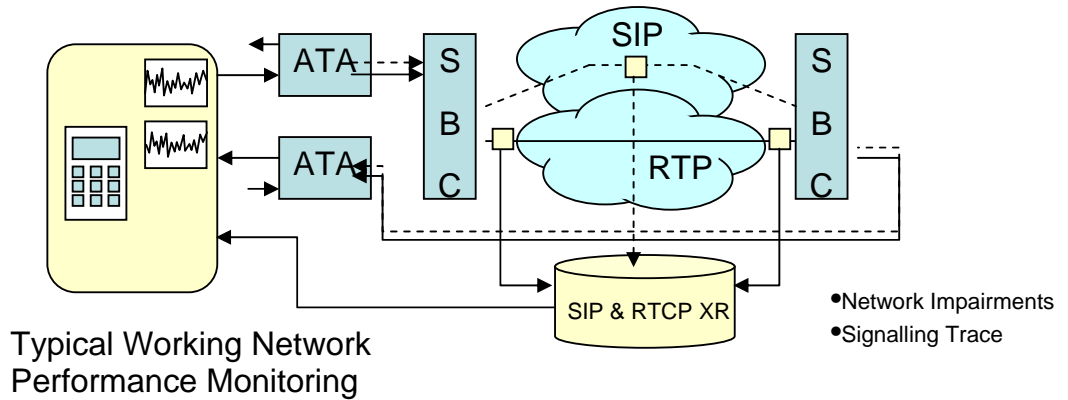

FIGURE 6

Typical Working Network Performance Monitoring

B6 Operational Test Configuration 2 – Suggested Low-Cost Test Setup

- B.6.1 Use a Network reflector to test right across the network from a single network test point. This may be useful for smaller operators e.g. where an initial test set up might be expensive but it is relatively inexpensive to deploy reflectors.
- B.6.2 Figure 7 shows calls transiting via a gateway, but the preferred approach is to stay within one IP network where possible.
- B.6.3 This setup can capture RTCP information and provide a reasonably good indication of service performance.

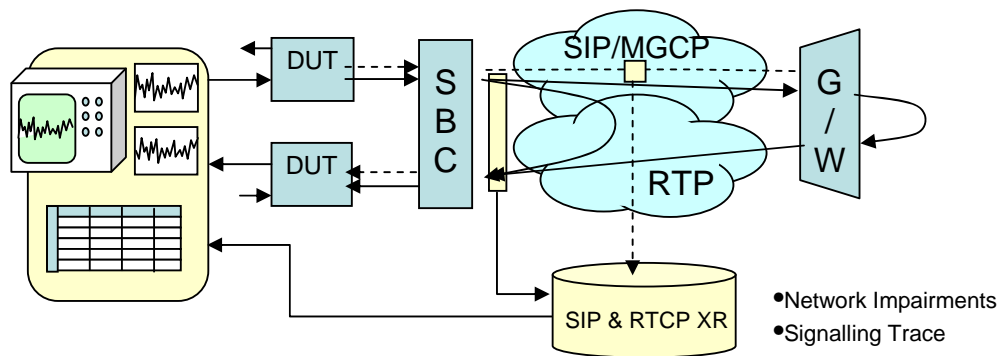

FIGURE 7

Single Ended Test Setup

APPENDIX

C Configuration for Upfront Quality Assessment (Design Testing)

C1 Introduction

C.1.1 This Appendix provides information on upfront quality assessment in relation to:

- (h) standard test conditions;
- (i) possible testing methods; and
- (j) possible test configurations.

C.1.2 The information included here does not limit the options for upfront quality assessment.

C2 Standard Test Conditions

C.2.1 Unless this Guideline provides otherwise, testing for compliance with this Guideline should be conducted at the nominal supply voltage of the CE and within the following ranges of atmospheric conditions:

- (a) An ambient temperature in the range of 15°C to 25°C inclusive.
- (b) A relative humidity in the range of 30% to 75% inclusive.
- (c) An air pressure in the range of 86 kPa to 106 kPa inclusive.

C.2.2 On 2-wire circuits intended for connection of analogue handsets conforming to AS/ACIF S002, tests should be conducted into the TN12 reference impedance in Figure 8.

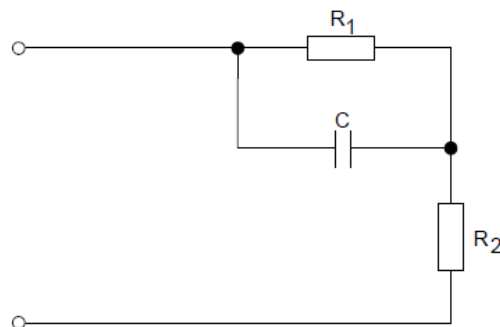

$R_1 = 820 \Omega \pm 0.1\%$
 $R_2 = 220 \Omega \pm 0.1\%$
 $C = 115\text{nF} \pm 0.1\% \text{ or } 120\text{nF} \pm 0.1\%$

FIGURE 8

AS/ACIF S002 analogue handset reference impedance (TN12)

C3 Upfront Quality Assessment Conditions

- C.3.1 Design verification tests are conducted under maximum rated network load, as shown in Figure 9, with:
- (a) Recommended equipment settings for levels, codecs, RTCP reporting, priority queuing, line settings, etc.
 - (b) The minimum recommended speed for the broadband service.
 - (c) The intended configuration of the IP network equipment, carrying realistic external traffic.
 - (d) Simultaneous file transfers occur at A and B, at a lower priority than the voice call, for the duration of the test.
- C.3.2 In Figure 9, User A performs file upload, and B performs file download.
- C.3.3 For design verification tests:
- (a) Test equipment generates standard test signals e.g. from a signal generator.
 - (b) ECANs are allowed to converge in both directions, by feeding the ITU-T Rec. P.501 file CSEC_8K.wav (pulsed white noise) in the direction from B to A, and then playing the same file in the opposite direction.
 - (c) It is assumed that the terminal equipment is able to measure IPDV, IPTD and IPLR according to RTP standards (refer to RFC 3550). This may be read from the CE, or intercepted in the IP network.
- C.3.4 In the case of multi-channel IADs/ATAs:
- (a) The rated maximum number of simultaneous voice calls is set up between A and B, and held for the duration of the test.
 - (b) Identical test sequences are fed into all calls at the A end, simultaneously.
 - (c) The required number of test measurements are taken across all the simultaneous calls.

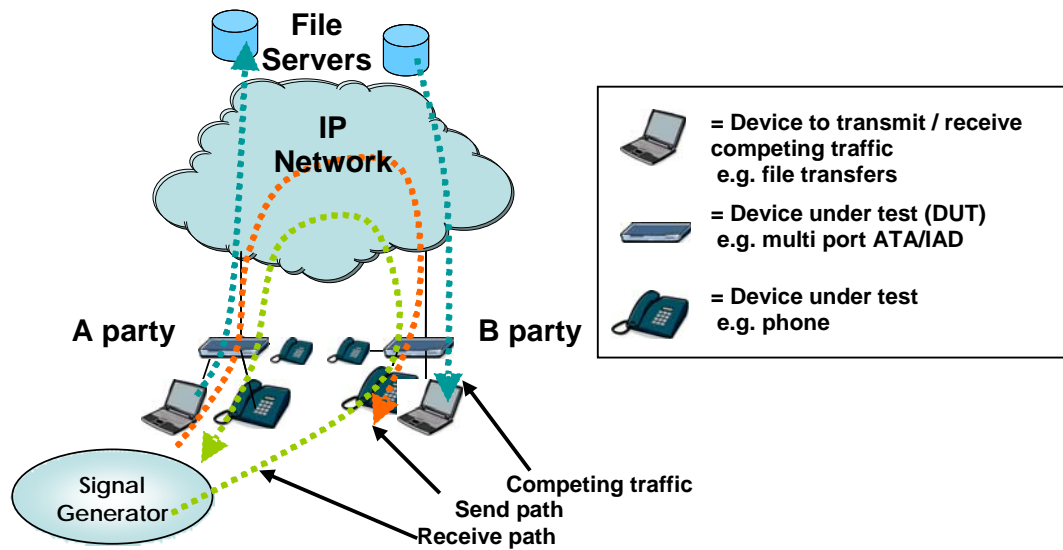

FIGURE 9
Standard Test Conditions

C4 Design Test Configuration 1 – Electrical Interface

- C.4.1 The test configuration in Figure 10 is applicable to devices with an electrical interface, e.g. IAD, ATA, mobile phone with a handsfree kit.
- C.4.2 Standard test signals come from an audio source e.g. CD player.
- C.4.3 In Figure 11, "Z" performs the following functions:
 - (a) Providing electrical isolation
 - (b) Matching the standard TN12 impedance on 2-wire circuits.
 - (c) Matching the level from the audio source (e.g. CD player) to the equipment.
- C.4.4 For scenarios involving one or more multi-channel ATAs one should use more than one audio source.
- C.4.5 This test configuration does not assume that the tester has access to the jitter buffer inside the IAD (as occurs in testing under ITU-T Rec. P.564).

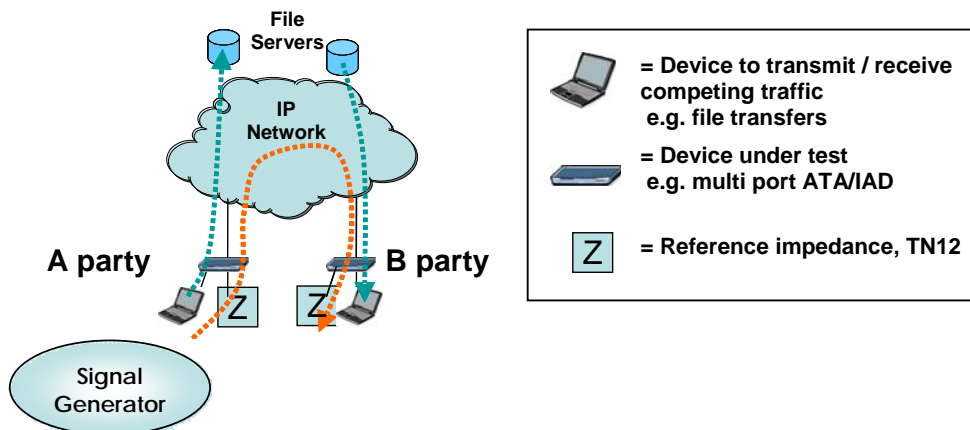

FIGURE 10
Electrical Interface Test

C5 Design Test Configuration 2 – Acoustic Interface

- C.5.1 The test configuration in Figure 11 is applicable to devices with an acoustic interface e.g. SIP phones, mobile phones.
- C.5.2 T is a “Talking Head”, which converts electrical signals to and from acoustic signals.

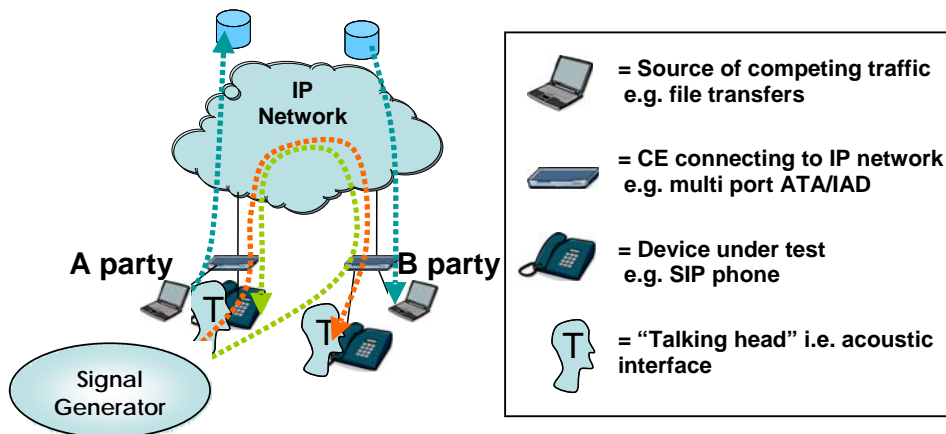

FIGURE 11
Acoustic Interface test

C6 HOW TO TEST VOIP SERVICE QUALITY - METHODS

Introduction

- C.6.1 The following test methods may be used for quantitative measurements that are required for E-Model assessment. A Digital Storage Oscilloscope (DSO) is used to take the measurements.

C7 Mouth-to-Ear delay

- C.7.1 This test (refer to Figure 12) is conducted under maximum rated network load, with:
- (a) The Maximum rated number of simultaneous voice calls set up between A and B.
 - (b) The file P.501 CSEC_8K.wav (pulsed white noise) is played repeatedly in the direction A to B, without gaps.
 - (c) All calls fed with the same test signal, at A.
- C.7.2 Mouth to Ear Delay is measured every 10 seconds.
- C.7.3 Mouth-to-Ear Delay is reported in ms, as the average of 10 readings, or 90% of the largest reading, whichever is the larger.
- C.7.4 If there are multiple channels, the same signal is fed into the maximum number of channels which the device is claimed to support, and the measurements are sampled across all channels at the B end.
- C.7.5 To test, inject tone pulses, measure the end of the tone pulses on one DSO trace, then compare the end of the tone pulses on another DSO trace to obtain a measure of delay.

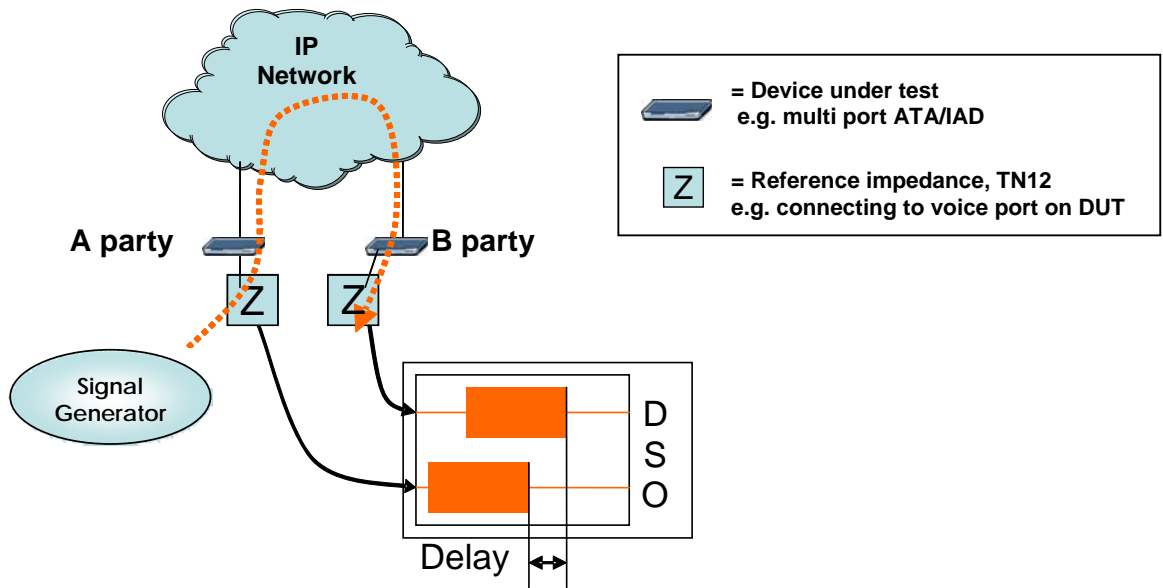

FIGURE 12
Mouth-to-Ear delay for design testing

C8 IP Packet Loss Ratio

- C.8.1 IPLR for a VoIP Service is measured during the tests in section 4, taking the IPLR at the end of the call (at least 3 minutes).

NOTE: As stated in clause 4.1.1, a VoIP Service is measured from mouth to ear. This is different from measuring between user-network interfaces for QoS on an IP Network (refer to G632 for more information on network level measurements, including for IPLR).

- C.8.2 IPLR is reported as the ratio of packets lost across all simultaneous channels to the number of packets sent, across all simultaneous channels.
- C.8.3 The IPLR may be measured by:

- (a) reading the IPLR at the B party (on packets received from the A party), or

NOTE: An IPLR value obtained from RTP statistics includes packet loss in the network(s) and does not include packet loss in CE e.g. due to jitter.

- (b) intercepting the RTCP-XR statistics in the IP network.

NOTE: An IPLR value obtained from RTCP-XR statistics should include packet loss in the network(s) and packet loss in CE e.g. due to jitter.

C9 Validation of Echo Canceller Convergence - Terminals

- C.9.1 This test (refer to Figure 13) is used to ensure that an ITU-T Rec. G.168 ECAN in 2-wire terminal equipment is converging when connected to Australian CE.

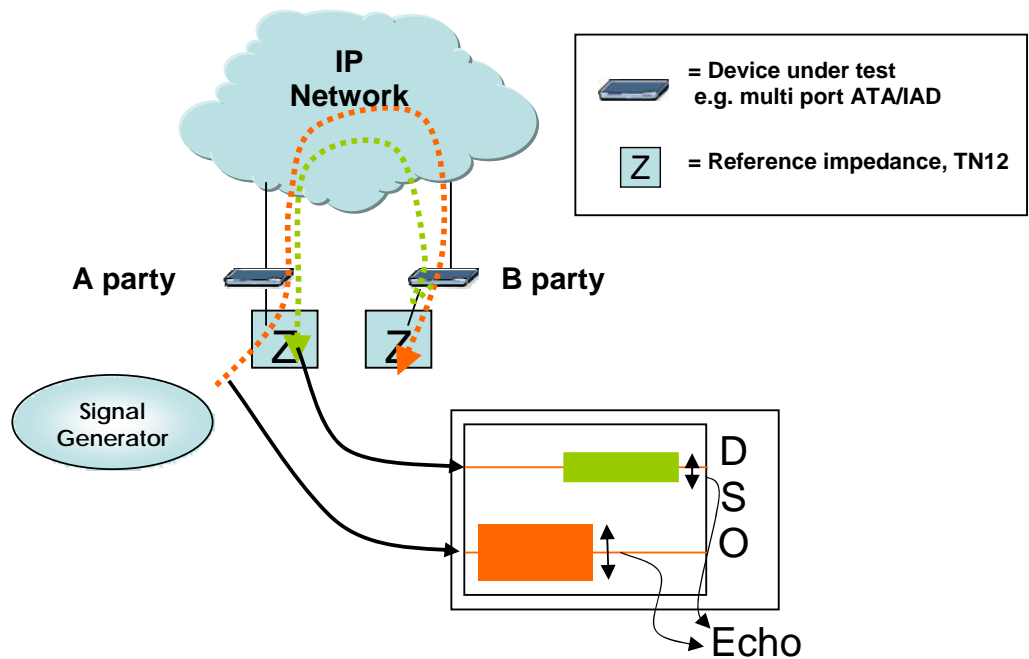

FIGURE 13

Validation of Echo Canceller Convergence – IAD/ATA for design testing

- C.9.2 Apply CSEC_8K.wav to A, and measure the amplitude of the returned echo. With consideration only to the echo canceller convergence, Echo Return Loss (ERL) must be > 50dB; in the end-to-end test scenario, the TELR should be as close to 65dB as possible.
- C.9.3 If there is no ECAN, or the ECAN does not conform to G.168, then ERL should be measured. This is performed from a 4-wire point, as shown in Measurement of Echo Loss refer to Figure 16 below).

C10 Validation of Echo Canceller Convergence - Gateways

C.10.1 This test (refer to Figure 14) is used to ensure that an ITU-T Rec. G.168 ECAN in TGWs is converging when connected to the Australian PSTN.

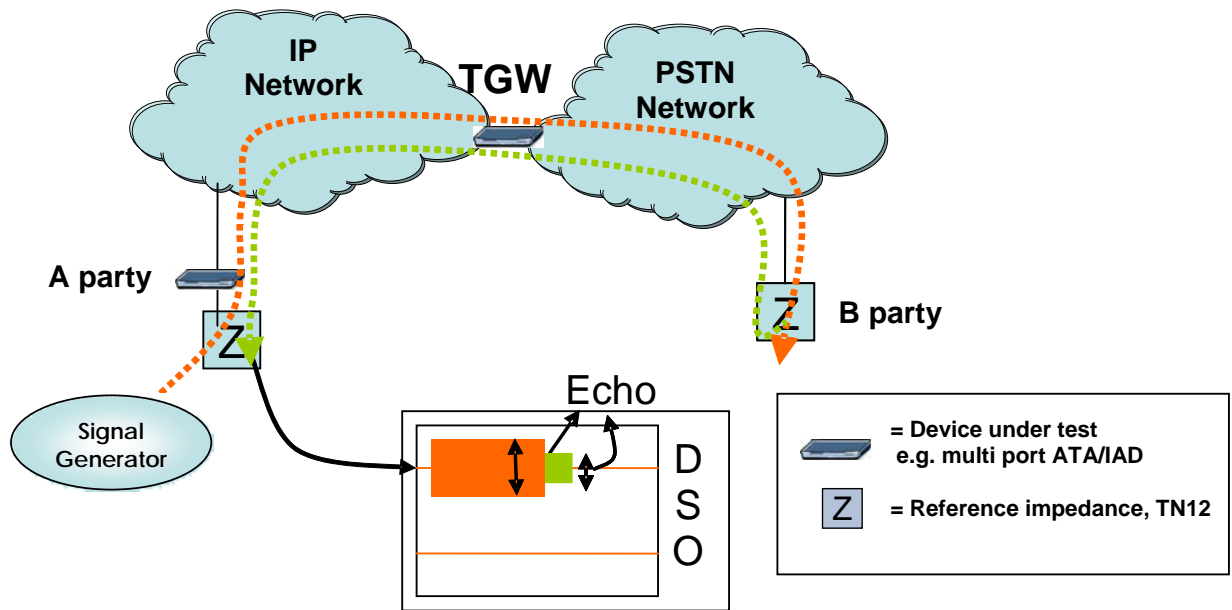

FIGURE 14

Validation of Echo Canceller Convergence – Gateways for design testing

- C.10.2 Delay in the PSTN must be the longest path expected. One-way delays of up to 30ms (60ms round-trip delay) receive no ECAN in the Australian PSTN.
- C.10.3 Apply CSEC_8K.wav to A, and measure the amplitude of the returned echo.
- C.10.4 TELR should be as close as possible to 65dB.

C11 Measurement of Echo Loss

C.11.1 This test (refer to Figure 15) is used to measure the effectiveness of ECAN in VoIP equipment where the ECAN is not based on ITU-T Rec. G.168, or where the codec type is unknown. The signal is injected into the TGW from a 4-wire point (e.g. using an ISDN interface into the PSTN).

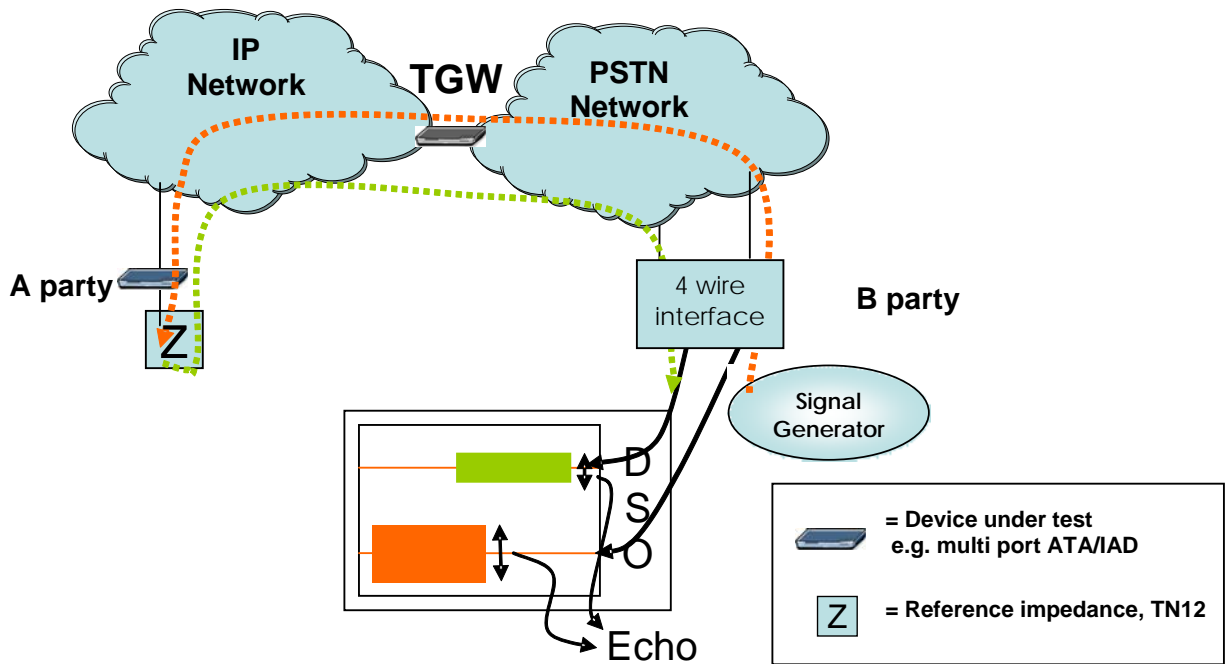

FIGURE 15
Echo Return Loss

C.11.2 Voiceband CE and voice only CE shall provide return loss, and terminal balance return loss values meeting the requirements of the masks specified in ETSI ES 201 168, when measured using a TN12 reference impedance.

C12 Loss Plan

C.12.1 SLR and RLR have a major impact on the R value. Default values for SLR and RLR on analogue handsets conforming to AS/ACIF S002 are available in Table 1 of AS/ACIF S004. If the loudness rating value for the call scenario under test is unknown then one should either use a known value or measure the loudness rating.

C.12.2 The loudness rating should be measured with a reference codec. This codec may be another IP phone with a known loudness rating, or measured from the PSTN via a TGW at a 0dB_r point (e.g. in practice, using a 4-wire point such as an ISDN line).

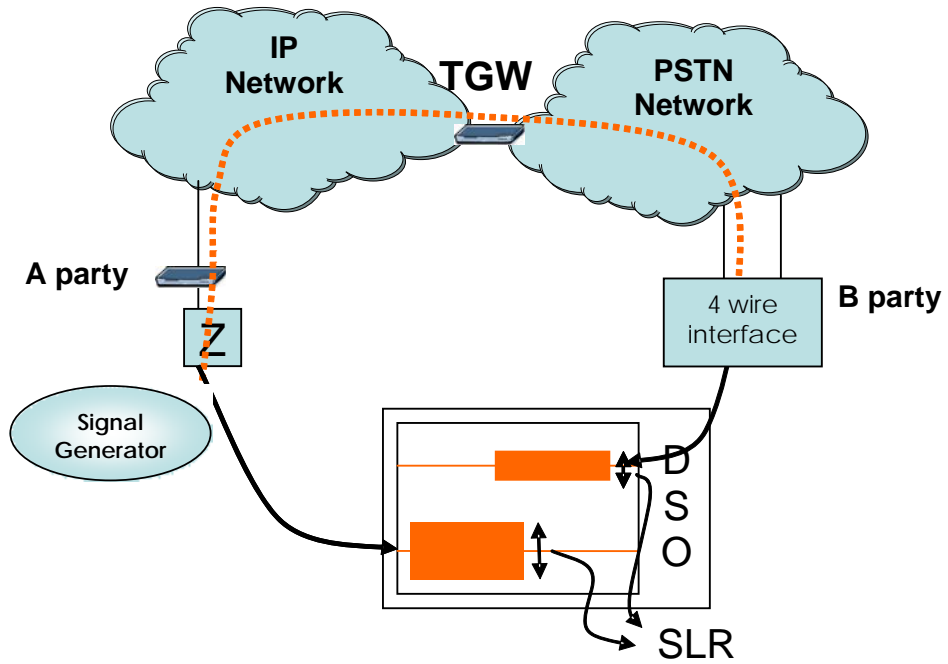

FIGURE 16
Send Loudness Ratings

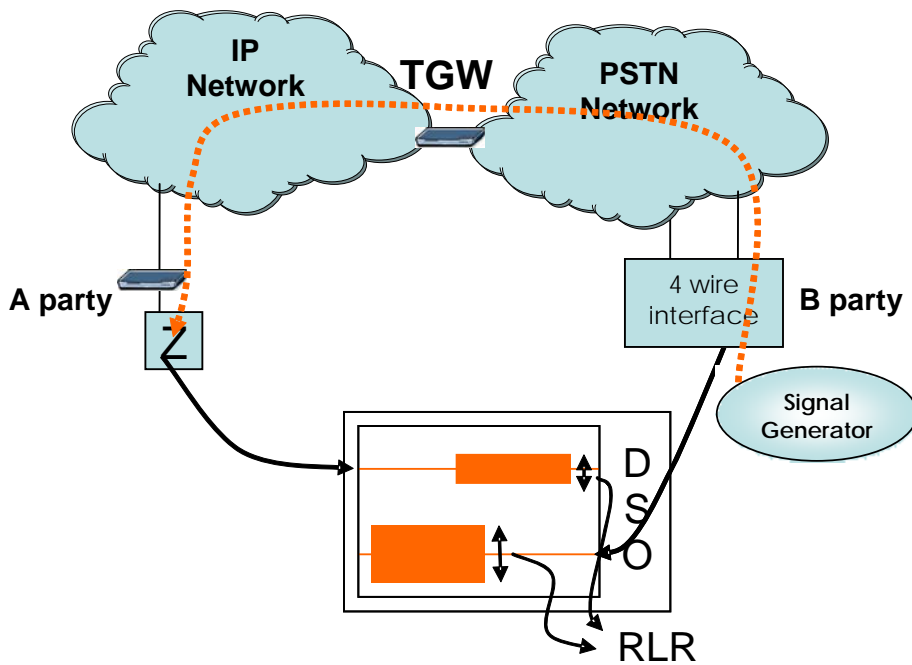

FIGURE 17
Receive Loudness Ratings

- C.12.3 Measure SLR from the electrical port of an IAD or the microphone of an artificial head to a four wire point (refer to figure 16).

NOTE: Measuring at a 4-wire point allows one to make separate measurements of the SLR and RLR. This contrasts with measuring at a 2-wire point where OLR (= SLR+RLR) can be measured the send and receive signals are mixed. For each equipment scenario, a method of conducting a 4-wire test is to place a call to a TDM based endpoint and testing at that endpoint, however this only works for use with a G.711 codec and in a number of scenarios would not be testing 'like for like'.

- C.12.4 Measure RLR from a four wire point to the electrical port of an IAD or the earpiece of an artificial head (refer to figure 17).
- C.12.5 If the receiver has a volume control, the vendor may select any RLR in the range of the volume control.
- C.12.6 If the transmitter has automatic gain control (AGC), the equipment supplier may select any SLR in the range of the AGC.

APPENDIX

D Examples of base case calculations

D1 Introduction

- D.1.1 The following examples were derived from ITU-T Rec. G.108 Amendment 2, with values adapted for Australian PSTN telephones, and G632.
- D.1.2 The following information is relevant for Echo and Loudness Rating:
- (a) $TEL_R = SLR + EL + RLR$ where SLR & RLR are characteristics of the telephones and EL is the Echo Loss, the sum of all losses in the echo path exclusive of SLR and RLR.
 - (b) TCLw is a single number that indicates how well the telephone attenuates its echo signal. Both ITU-T Rec. P.1010 and AS/ACIF S004 (refer to clause 5.4.3.5.1) state that TCLw for VoIP CE should exceed 55dB.
 - (c) The examples below use $TCL_w = 55\text{dB}$. However, it is recommended that the TCLw value is measured, noting the need to use white noise in the test.
 - (d) Refer to section 4.6.11 in G634 for discussion of the optimum OLR values.
- D.1.3 Some of the Figures below indicate the values used for Echo and Loudness Rating in the corresponding examples.
- D.1.4 The following examples assume there is sufficient bandwidth for the number of simultaneous calls and background traffic.

D2 Example 1 – VoIP terminals with G.711 and WAN according to Y.1541 Class 0

- D.2.1 For the E-model calculations, the following scenario for terminal delay was investigated:
- (a) VoIP-phone to VoIP-phone, assuming echo cancellation is in operation.
 - (b) VoIP terminal send delay $T_s = 22\text{ ms}$, consisting of 20ms packetisation, G.711 codec (i.e. no speech encoding) and 2ms packet processing in the telephone.
 - (c) VoIP terminal receive delay $T_r = 39\text{ ms}$ consisting of 32ms jitter buffer, 2ms packet processing and 5ms packet loss concealment.

- (d) Mean network delay $T_{wan} = 100\text{ms}$ which includes access and transit IP segments within Australia.
- (e) Total delay = $T_s + T_{wan} + T_r = (22 + 100 + 39) \text{ ms} = 161 \text{ ms}$.
- (f) The ECAN in the IP Phone (if used) must support the echo tail of the local handset, usually less than 10 ms.
- (g) Other parameters are as outlined in Figure 18 below.
- (h) Packet loss concealment is in use.

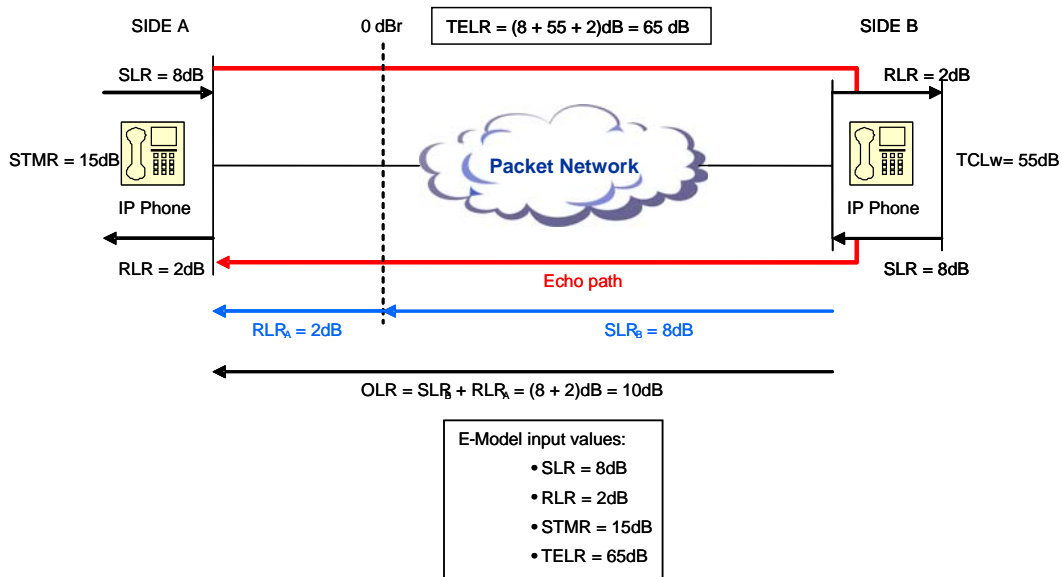

FIGURE 18

Example 1 TELR for VoIP terminals with G.711 and WAN according to Y.1541 Class 0

D.2.2 The result from the E model gives R = 89.1 (Users satisfied).

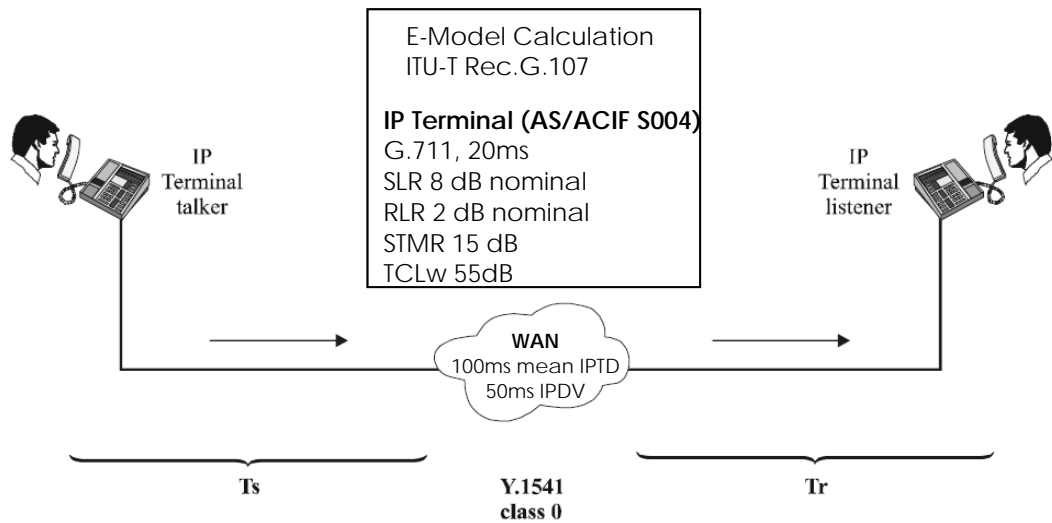

FIGURE 19

Example 1 VoIP terminals with G.711 and WAN according to Y.1541 Class 0

D3 Example 2 – VoIP islands with G.711 and PSTN

D.3.1 For the E-model calculations, the following scenario for terminal delay (and gateway delay) was investigated:

- (a) VoIP-phone to VoIP-phone, but with interconnect across the PSTN rather than over native IP.
- (b) VoIP terminal send delay $T_s = 22$ ms.
- (c) Mean IP access delay $T_{access} = 25$ ms.
- (d) VoIP terminal receive delay $T_r = 21$ ms, consisting of 14ms jitter buffer, 5ms PLC and 2ms packet processing. (The jitter buffer is smaller in this case as there is only one access segment.)
- (e) PSTN delay $T_{pstn} = 31$ ms, consisting of 30ms long-distance transmission (approximately 6000km) and two digital PSTN exchanges (0.5ms each).
- (f) VoIP gateway send delay $T_{gs} = 22$ ms.
- (g) VoIP gateway receive delay $T_{gr} = 21$ ms.
- (h) total delay = $T_s + T_{access} + T_{gr} + T_{pstn} + T_s + T_{access} + T_r$
= $(22 + 25 + 21 + 31 + 22 + 25 + 21)$ ms
= 167 ms.
- (i) Other parameters are as outlined in Figure 20 below.

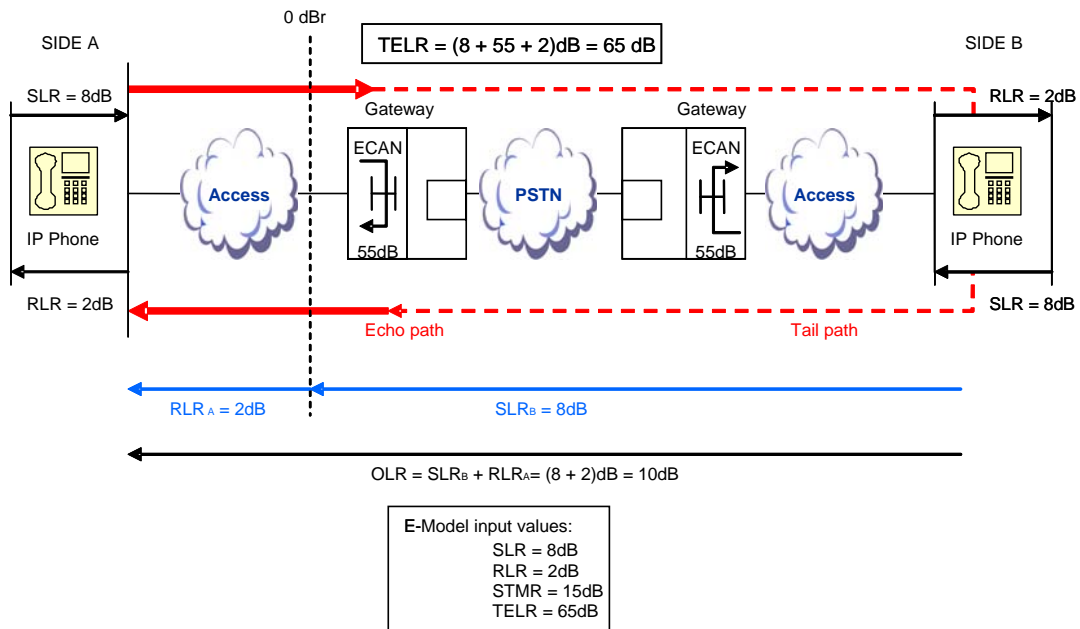

FIGURE 20

Example 2 – TELR for VoIP islands with G.711 and PSTN

- D.3.2 The result from the E model gives R = 88.8 (Users satisfied).
- D.3.3 This assumes the use of:
 - (a) packet loss concealment for G.711; and
 - (b) echo cancellation.

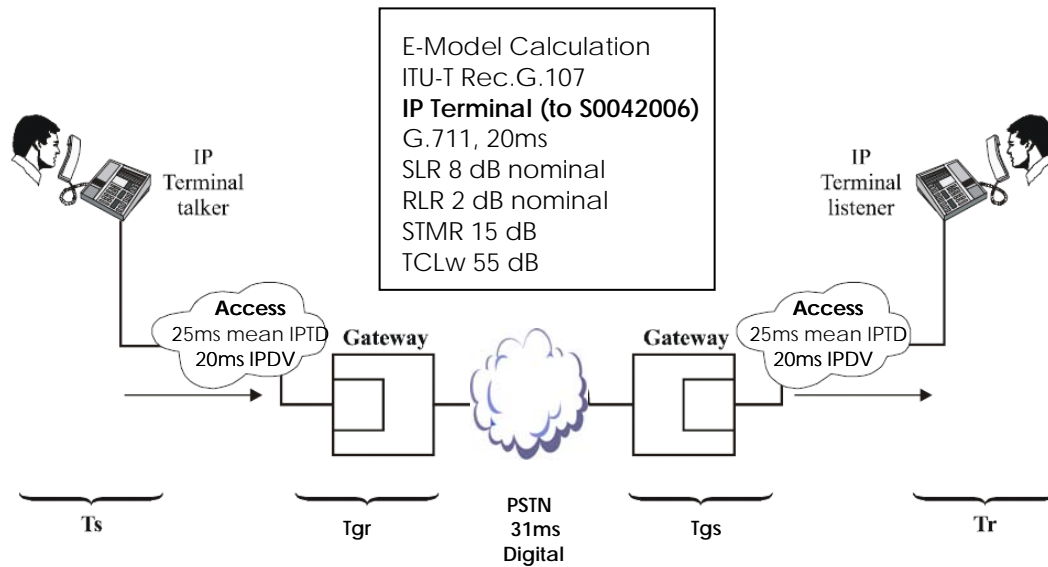

FIGURE 21

Example 2 – VoIP islands with G.711 and PSTN

D4 Example 3 – VoIP terminal with G.711 and PSTN with analogue terminal

D.4.1 For the E-model calculations, the following scenario for terminal delay (and gateway delay) was investigated:

- (a) VoIP-phone to PSTN and PSTN to VoIP phone scenarios (required due to the asymmetrical connection type), assuming echo cancellation is enabled in the TGW.
- (b) VoIP terminal send delay $T_s = 22$ ms.
- (c) IP access delay $T_{access} = 25$ ms.
- (d) VoIP terminal receive delay $T_r = 21$ ms, consisting of 14ms jitter buffer, 5ms PLC and 2ms packet processing. (The jitter buffer is smaller in this case as there is only one Access segment.)
- (e) VoIP gateway send delay $T_{gs} = 22$ ms consisting of 20ms packetisation, and packet processing of 2ms.
- (f) VoIP gateway receive delay $T_{gr} = 21$ ms, consisting of 14ms jitter buffer, 5ms PLC and 2ms packet processing. (The jitter buffer is smaller in this case as there is only one Access segment.)

- (g) PSTN transmission delay $T_{pstn} = 32$ ms, consisting of 31ms long-distance transmission plus 1ms for analogue conversion at the PSTN subscribers end. Paths of up to 34ms can occur in the PSTN without insertion of PSTN echo cancellers. An ECAN is required in the trunking gateway. This ECAN must be able to support an echo tail to the PSTN phone and back, a total of at least 68ms.
- (h) total delay IP to PSTN = $T_s + T_{access} + T_{gr} + T_{pstn}$
 = $(22 + 25 + 21 + 32)$ ms
 = 100 ms.
- (i) total delay PSTN to IP = $T_{pstn} + T_{gs} + T_{access} + T_r$
 = $(32 + 22 + 25 + 21)$ ms
 = 100 ms.
- (j) Other parameters are as outlined in Figures 22 and 23 below. Note this case is not symmetrical and thus the need of the two diagrams for each direction of the call.

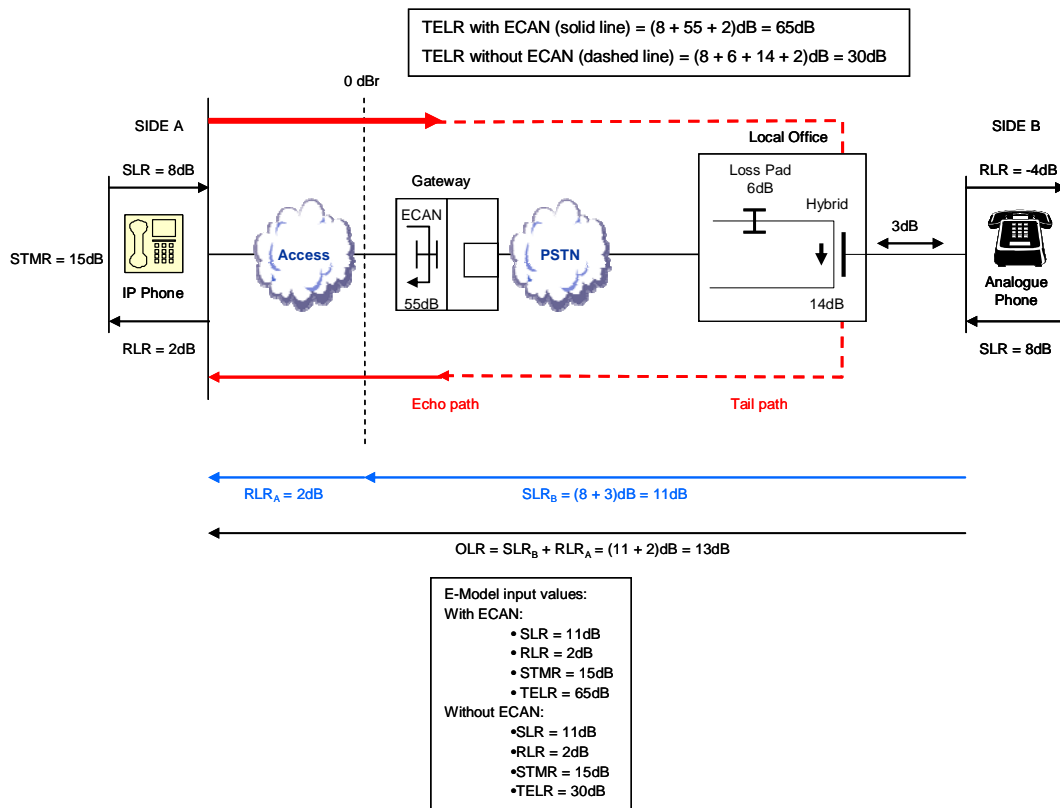

FIGURE 22

Example 3 – TELR for VoIP to PSTN case of VoIP terminal with G.711 and PSTN with analogue terminal

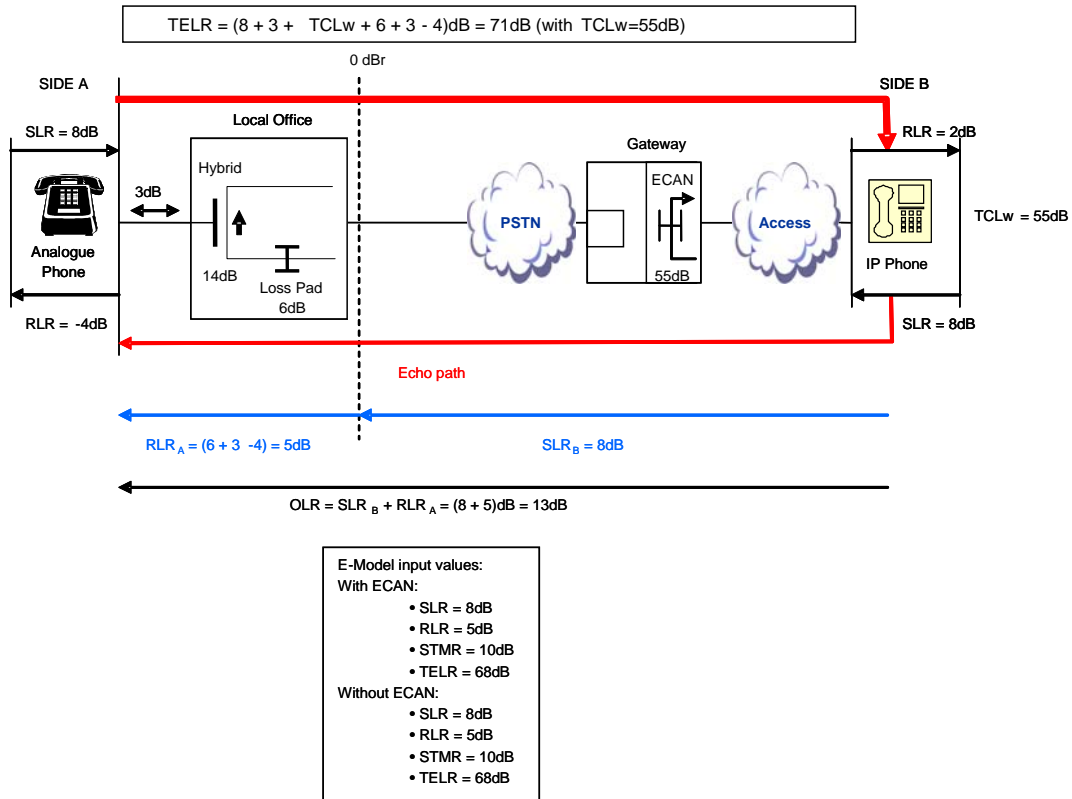

FIGURE 23

Example 3 - - TELR for PSTN to VoIP case of VoIP terminal with G.711 and PSTN with analogue terminal

D.4.2 The results from the E-Model give the R values in Table 1.

	IP to PSTN	PSTN to IP
With ECAN	86.6 (users satisfied)	87.9 (users satisfied)
Without ECAN	31.1 (not recommended)	87.9 (users satisfied)

TABLE 1

R values for Example 3 - IP to PSTN and PSTN to IP

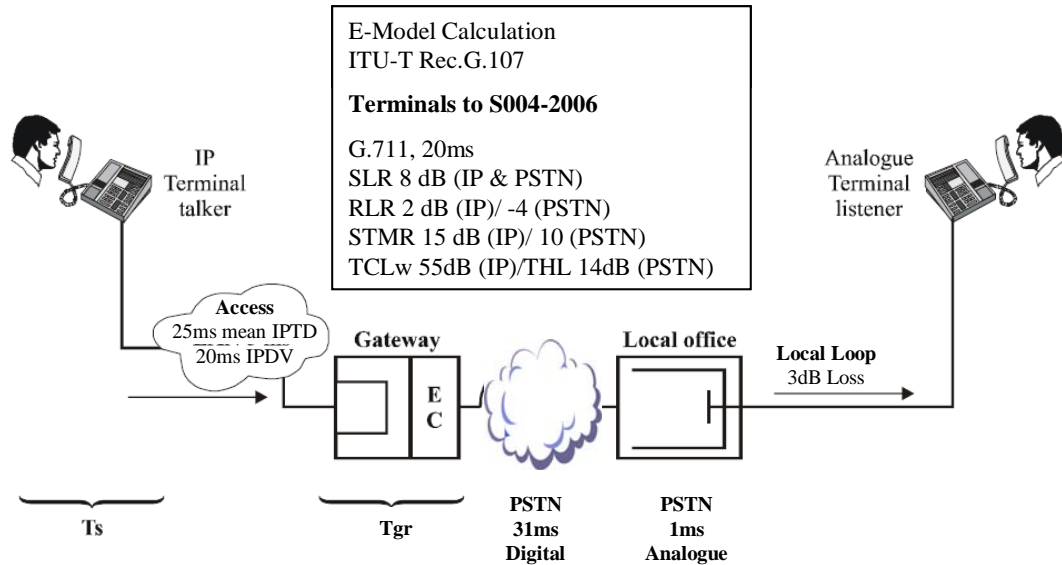

FIGURE 24

Example 3 - VoIP terminal with G.711 and PSTN with analogue terminal

D5 Example 4 – VoIP terminals with G.729a and WAN according to Y.1541 Class 0

D.5.1 For the E-model calculations, the following scenario for terminal delay was investigated:

- (a) VoIP-phone to VoIP-phone with a G.729a codec in use. Echo cancellers, if used, are located in the IP handsets.
- (b) VoIP terminal send delay $T_s = 25$ ms consisting of 10ms packetisation, 5ms look ahead, 8 ms speech coding and 2ms packet handling.
- (c) Mean Network delay $T_{wan} = 100$ ms.
- (d) VoIP terminal receive delay $T_r = 42$ ms, consisting of 32ms jitter buffer, 8 ms of speech decoding, and 2ms of packet processing.
- (e) Total delay = $T_s + T_{wan} + T_r$
 $= (25 + 100 + 42)$ ms
 $= 167$ ms.
- (f) Codec choice of G.729a means $l_e = 11$ (with VAD).
- (g) Other parameters are as outlined in Figure 25 below.

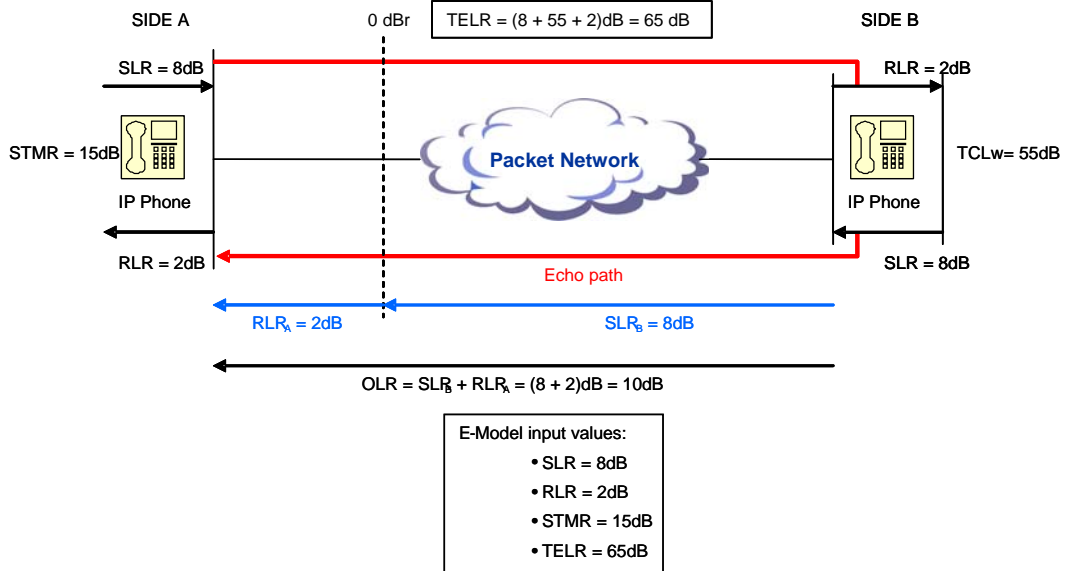

FIGURE 25

Example 4 – TELR for VoIP terminals with G.729a and WAN according to Y.1541 Class 0

D.5.2 Result from the E model gives R = 77.8 (some users dissatisfied)

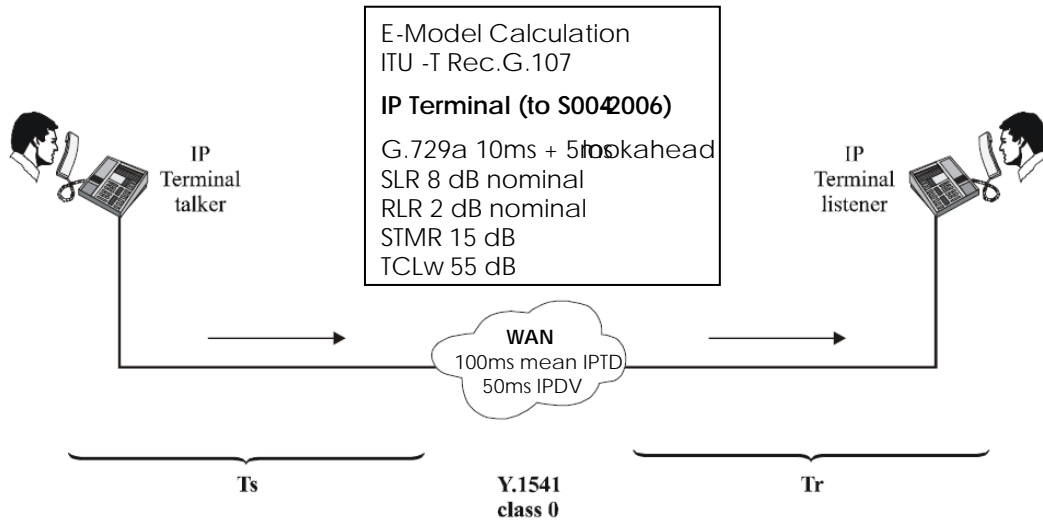

FIGURE 26

Example 4 – VoIP terminals with G.729a and WAN according to Y.1541 Class 0

PARTICIPANTS

The Working Committee that developed the Guideline consisted of the following organisations and their representatives:

Organisation	Membership	Representative
AAPT	Voting	Peter Crosby
AAPT / PowerTel	Non-Voting	Peter Kohlmayer
ACCC	Non-Voting	Rowan Groves
ACMA	Non-Voting	Noel Buchanan
Alcatel-Lucent	Voting	Evan Stanbury
Cisco Systems	Voting	Kim Yan
Nortel	Voting	Julio Cadena
Pacific Internet	Voting	Gary Marshall
SingTel Optus	Voting	James Dam
TEDICORE	Voting	Barry Dingle
Telstra	Voting	Glenn Colville
Telstra	Non-Voting	Chris Hill
Vodafone	Voting	Davorka Karacic

This Working Committee was chaired by Gary Marshall.

James Duck of Communications Alliance provided project management support.

Communications Alliance was formed in 2006 to provide a unified voice for the Australian communications industry and to lead it into the next generation of converging networks, technologies and services.

In pursuing its goals, Communications Alliance offers a forum for the industry to make coherent and constructive contributions to policy development and debate.

Communications Alliance seeks to facilitate open, effective and ethical competition between service providers while ensuring efficient, safe operation of networks, the provision of innovative services and the enhancement of consumer outcomes.

It is committed to the achievement of the policy objective of the *Telecommunications Act 1997* - the greatest practicable use of industry self-regulation without imposing undue financial and administrative burdens on industry.



Published by:
**COMMUNICATIONS
ALLIANCE LTD**

Level 9
32 Walker Street
North Sydney
NSW 2060 Australia

Correspondence
PO Box 444
Milsons Point
NSW 1565

T 61 2 9959 9111
F 61 2 9954 6136
TTY 61 2 9923 1911
E info@commsalliance.com.au
www.commsalliance.com.au
ABN 56 078 026 507

Care should be taken to ensure the material used is from the current version of the Guideline and that it is updated whenever the Guideline is amended or revised. The number and date of the Guideline should therefore be clearly identified. If in doubt please contact Communications Alliance.